



FM-Tco4 HCV / HCV 3G / HCV BT User Manual

2018/05

Table of contents

- 1 Preface..... 2
 - 1.1 Use of this document 2
 - 1.2 Document change log 2
- 2 Introduction..... 4
 - 2.1 Purpose 4
 - 2.2 Acronyms..... 4
 - 2.3 Legal information..... 4
 - 2.4 Safety..... 4
 - 2.5 References..... 5
- 3 Device description 7
 - 3.1 About 7
 - 3.2 Package contents 7
 - 3.3 Physical characteristics..... 8
 - 3.4 Technical characteristics..... 8
 - 3.5 IO pin out 10
 - 3.6 Interfaces and peripheral accessories 11
 - 3.7 Certification..... 12
 - 3.8 LED status 12
 - 3.8.1 GNSS LED 12
 - 3.8.2 GSM LED 13
 - 3.8.3 Peripheral LED 13
 - 3.8.4 LED status in sleep and deep sleep modes 14
- 4 Device configuration 15
 - 4.1 Driver installation..... 15
 - 4.2 Sample configuration 17
 - 4.3 Advanced configuration..... 19
 - 4.3.1 Global settings 21
 - 4.3.2 Profile settings 28
 - 4.3.3 IO settings 33
 - 4.4 Integration protocol 44
- 5 Installation recommendations..... 45
 - 5.1 Device installation..... 45
 - 5.2 FM-Tco4 HCV BT device 45
 - 5.3 Antenna installation 45

1 Preface

1.1 Use of this document

This document provides required information for proper device handling, preparation, configuration and installation to a vehicle. This document has a linear structure – from the device package box reception to the recommendations on how to install the device to the vehicle. However it is not overfilled with unnecessary information. You will find only basic descriptions about various functions and actions needed to start using the device. Additionally, there will be references to a more detailed descriptions.

The following markings are used to highlight important information:

- Notes contain important information that you need to pay attention to.

Note

Notes like this contain important information!

- Actions and various elements of the software required for configuration of the device are marked in **bold**.
- All actions are described in sequence in the following five sections: Introduction, Device description, Device preparation, Device configuration and Installation recommendations.

1.2 Document change log

Date	Version	Change details
2016-06-16	1.0	Initial draft.
2016-06-23	1.1	Added "LCV Autoselect" description in "IO settings" chapter.
2016-08-19	1.2	Added information about FM-Tco4 HCV with Bluetooth module in "Technical characteristics", "Global settings" and "Installation recommendations" chapters.
2016-08-29	1.3	Added FW and FM4 configurator compatibility check description in "Advanced configuration" chapter. Added "Shock detection" description in "Global settings" chapter.
2016-10-14	1.4	Added "CAN HCV" and "DXP CAN" modes descriptions in the "IO settings" chapter.
2016-11-29	1.5	Information about FM-Tco4 HCV BT device in "Technical characteristics", "Global settings" and "Installation recommendations" chapters.
2016-12-13	1.6	"Constant TCP link" functionality description in "Profile settings" chapter.
2017-01-30	1.7	In the "IO settings" chapter: "LCV auto select" description updated. "CANbus data filter by engine state" described. "Keep TCO parameter values when engine is OFF" described.
2017-03-09	1.8	Changed DIFF file description in "Advanced Configuration" chapter.
2017-03-24	1.9	DTC from J1939 and J1708 modes. 1-Wire interface added. Factory reset description.
2017-04-21	1.10	"GSM tracking" feature description and option to enable/disable SIM status feature in "Global settings" chapter.
2017-05-18	1.11	Configurable sleep mode description in "Profile settings" chapter. Sleep mode configuration no longer interferes with sleep mode functionality.
2017-06-07	1.12	Automatic IO enable function in IO setting chapter. Added description of "Calc HRFC" and "FF value" filter in CAN HCV mode. Added LCV Autoselect "Enable I/Os" function description.

2017-07-15	1.13	Removed notes regarding the absence of the audio interface. Revision of technical characteristics. Added information regarding the configurable DIN3 mode. Minor changes in the "Authorized numbers" section.
2017-08-10	1.14	New section added regarding the "Custom SMS alert text".
2017-08-30	1.15	Debounce description added in "IO settings" section.
2017-09-11	1.16	Added notes regarding LCV+OBD and FMS+OBD configuration.
2017-09-27	1.17	New K-line interface mode "Tacho read".
2017-10-18	1.18	Added "Configuration information" description in the "Sample configuration" section.
2017-12-22	1.19	Added description of "SSL authentication" in the "Global settings" section. Added description of "Link settings – Heartbeat" in the "Profile settings" section. Added note regarding greyed out fields in "Global settings".
2018-03-08	1.20	Added description for configurable audio volume and microphone gain. Added description for negative DIN4. Removed LCV CAN bus reading support.
2018-05-11	1.21	Added description of automatic firmware update from configurator.

2 Introduction

2.1 Purpose

The purpose of this document is to provide physical and technical data of the device, to explain device's behaviour and how various conditions are indicated. Device preparation for the operation and its configuration instructions are included as well.

2.2 Acronyms

PC – Personal Computer;
GPRS – General Packet Radio Service;
GPS – Global Positioning System;
GSM – Global System for Mobile Communications;
GLONASS – Global Navigation Satellite System;
GNSS – Global Navigation Satellite System;
SMS – Short Message Service;
AC / DC – Alternating Current/Direct Current;
PCB – Printed Circuit Board;
LED – Light Emitting Diode;
I / O – Inputs / Outputs;
2G – second generation of mobile telecommunications technology;
3G – third generation of mobile telecommunications technology;
UMTS – Universal Mobile Telecommunications System;
BT – Bluetooth;

2.3 Legal information

Copyright © 2018 Ruptela. All rights reserved. Reproduction, transfer, distribution or storage of parts or all of the contents in this document in any form without the prior written permission of Ruptela is prohibited. Other products and company names mentioned in this document are trademarks or trade names of their respective owners.

2.4 Safety



All the associated (additional) equipment such as PC's, batteries, sensors etc., shall meet the requirements of standard EN60950-1.



Do not disassemble the terminal. If the enclosure of the terminal is damaged, or the insulation of wires is damaged, first of all disconnect power supply cables from power supply source.



All of the wireless data transferring equipment produces interference that may affect other devices, which are placed nearby.



The terminal can be installed or dismantled only by qualified personnel!



The terminal must be firmly fastened in the predefined location. Predefined location is described in the mounting instructions.



The programming must be performed using a 2nd safety class PCs (with an autonomic power supply).



Make sure that the terminal is installed in a place, where it will not be subjected to harsh environmental conditions for extended time periods.



Caution! If an incorrect type of battery is used for replacement, there is a high explosion risk. Dispose used batteries according to the environmental requirements.



Any installation and/or handling during a lightning storm is prohibited.



For configuration use cables that were purchased from Ruptela. Ruptela is not responsible for any harm caused, while using wrong cables for the PC ↔ Terminal connection.



Attention! Do not connect the wires marked red (power supply) and black (chassis) to the wrong battery poles. Device has a reverse polarity protection, however if connected incorrectly, the device will not work



To disconnect the device from the power supply, you need to disconnect 12 PINs plug from the device or disconnect the wires from the vehicle's power supply.



This crossed-out wheelie bin symbol means that waste equipment should not be disposed of with your other household waste. The product must be taken to separate collection points at the product's end-of life.

This chapter contains procedures to help you safely operate the FM terminal. By following these requirements and recommendations, you will avoid dangerous situations. You must read these instructions carefully and follow them strictly before operating the device! The terminal is supplied from a car battery with these ratings: 12/24 V DC. The allowed voltage range from the battery is from 10 volts to 32 volts DC. Max. current for FM-Tco4 HCV is 250 mA @ 12 V DC. Max. current for FM-Tco4 HCV 3G/ HCV BT is 350 mA @ 12 V DC.

To avoid mechanical damage, it is advised to transport the FM terminal in an impact-proof package.

Before connecting wires of the 12 PIN cable to the vehicle, it is recommended to ensure that the cross-sectional area of wires mounting is at least 0.75 mm².

To correctly dismount the terminal from the vehicle, first of all disconnect power supply wires (12 PIN connector). Only then other plugs or interfaces can be disconnected.

The terminal is intended to be installed in a restricted access location, which is not accessible for the operator.

2.5 References

This document is designed to work in a conjunction with other documents. Documentation is kept light, unnecessary information is omitted. Additional and extensive explanations can be found in the documentation referenced below:

- FM-Tco4 HCV / HCV 3G / HCV BT Datasheets – Contains technical data of the FM-Tco4 HCV / HCV 3G / HCV BT device. Datasheets can be acquired from support@ruptela.com
- [Quick start guide](#) – A quick guide for a better understanding of the device configuration process and functions.
- [Peripheral accessories](#) – Instructions on how to use peripheral accessories together with the FM-Tco4 HCV / HCV 3G / HCV BT device.
- [Website link](#) – Our documentation website that contains the most recent versions of firmware, configurator and sample configuration files.

- [Microsoft Framework](#) – This additional software is required in order to run our configurator.
- [VCOM drivers](#) – Drivers required for device connection to PC.

All links are also provided in corresponding sections, where additional information might be needed.

Note

Ruptela documentation website address: doc.ruptela.lt

3 Device description

3.1 About

Ruptela's FM-Tco4 HCV / HCV 3G / HCV BT is 4th generation advanced, low power consumption but powerful tracking device. It acquires its position by a GPS/GLONASS signal and transfers data to a server via cellular 3G or GSM/GPRS network.

3G network support was not previously available for FM4 devices. This new feature in FM-Tco4 HCV 3G is the main advantage over the FM-Tco4 HCV devices.

FM-Tco4 HCV BT device contains Bluetooth module. This feature further extends its accessories list and adds new configuration capabilities.

Some of other FM-Tco4 HCV / HCV 3G / HCV BT features:

- 1-wire interface
- USB power supply for configuration
- 2 x RS232 and 1 x RS485 ports that function at the same time
- Dual CAN support (for FMS and tachograph connection)
- Data from accelerometer for ECO-Drive
- OBD functionality on standard firmware
- ThermoKing, Optitemp, Weighting system, Garmin support



FM-Tco4 HCV



FM-Tco4 HCV 3G



FM-Tco4 HCV BT

3.2 Package contents

FM-Tco4 HCV / HCV 3G device is supplied in cardboard package. GPS/GLONASS antenna and IO cables are disconnected from device. Package contents:

- FM-Tco4 HCV / HCV 3G / HCV BT device
- 12 PINs and 14 PINs cables
- GPS/GLONASS all-in-one antenna



Note

Providing a SIM card is optional, according to your payment plan. The SIM card is necessary for connection to the GSM network. The SIM card can be obtained from your local GSM service provider. The SIM card can work with the terminal only when all SIM card security codes are disabled.

3.3 Physical characteristics

Properties

Enclosure dimensions	111 x 75 x 25 mm
Indication	3 LEDs: Sat. status, GSM status, Periph. status
Housing	Plastic
External elements	GPS/GLONASS all-in-one antenna
Configuration interface	USB
Connectors	12 & 14 PINs

3.4 Technical characteristics

¹ Power consumption @ 12V	FM-Tco4 HCV	FM-Tco4 HCV BT	FM-Tco4 HCV 3G
Idle mode, mA	50	60	70
Sending records, mA	180	210	150
Deep sleep mode, mA	22	22	22

Ambient temperature ratings, °C	
Temperature range for device (without battery)	
Storage temperature, °C	-40 ~ +70
Operating temperature, °C	-35 ~ +70
² Temperature range for battery	
Charge, °C	0 ~ +45
Discharge (operating), °C	-20 ~ +60
Storage, °C	-20 ~ +70

Electrical and internal elements	
Power supply range	10-32 V DC
Absolute maximum ratings	50 V @ 60 s 72 V @ 0.1 s
Internal power supply	Li-Po 3.7 V, 1050 mA
Digital input threshold	4 V
Analogue input resolution	12 bit
GPS/GLONASS module	Ublox EVA-M8M
Channels	72
Sensitivity	-164 dBm
GPS/GLONASS antenna	External
Frequency	1575.42 ± 3 MHz
GSM modem	Quectel M95
Bands	850/900/1800/1900 MHz @ GSM
GSM antenna	Internal, Quad band
³ GSM/UMTS modem	Quectel UG96
Bands	800/850/900/1900/2100 MHz @ UMTS 850/900/1800/1900 MHz @ GSM
GSM/UMTS antenna	Internal, Quad band
⁴ Bluetooth	
Bluetooth LOW Energy 4.0	

Protections	
Short circuit protection	
Reverse polarity protection	
Electrostatic discharge protection on USB	
Electrostatic discharge protection on 1-wire	
Overcurrent protection on 1-wire power	
³ Charging protection	
⁵ ESD protection on SIM card slot	

¹ Firmware dependent; given values are valid when there are no peripheral devices attached. If battery is in charging mode, then power consumption in each mode will be higher within 170 mA.

² If temp is >45C, charging is disabled, if >60C battery is disconnected from the system at all.

³ Only for the FM-Tco4 HCV 3G device.

⁴ Only for the FM-Tco4 HCV BT device. Feature is currently under development.

⁵ Not soldered in standard version. Can be ordered.

3.5 IO pin out

12 PIN connector

Pin no.	Pin	Wire color	Description
1	10-32 V	Red	Power supply 12/24 V (range: 10-32 V)
2	Chassis	Black	Ground connection
3	DIN1	Pink	Digital input, threshold 4 V
4	AIN1	Gray	Analogue input (range: 0-30 V)
5	DIN2	Blue	Digital input, threshold 4 V
6	AIN2	Green	Analogue input (range: 0-30 V)
7	DIN3	White	Digital input, threshold 4 V
8	DOUT1	Purple	Digital output open collector up to 32 V, 1 A
9	DIN4	Yellow	Digital input, threshold 4 V
10	DOUT2	Orange	Digital output open collector up to 32 V, 1 A
11	CAN2 L	Blue/red	J1939 CAN interface low connection
12	CAN2 H	White/red	J1939 CAN interface high connection

14 PIN connector

Pin no.	Pin	Wire color	Description
1	PortB-232 RX	Yellow	RS 232 port B receive signal
2	Chassis	Black	Ground connection
3	PortB-232 TX	Orange	RS 232 port B transit signal
4	1W. +5V	Red	1-wire power supply +5 V, 200 mA
5	PortA-232 RX	Purple	RS 232 port A receive signal
6	1W. Data	Green/yellow	1-wire data channel
7	PortA-232 TX	Pink	RS 232 port A transit signal
8	CAN1 H	White	J1939 CAN interface high connection
9	L-Line	Green	J1939 CAN interface L line channel, diagnostics
10	CAN1 L	Blue	J1939 CAN interface low connection
11	K-Line	Brown	J1939 CAN interface K line channel, diagnostics
12	Chassis	Black	Ground connection
13	PortC-485 A	White/red	RS 485 differential signalling line A
14	PortC-485 B	Yellow/brown	RS 485 differential signalling line B

Note

Both CAN lines work at the same time. CAN1 is in 14 pin connector and CAN2 is in 12 pin connector. Connect your hardware to one of the interfaces and configure it accordingly.

3.6 Interfaces and peripheral accessories

There are several peripheral accessories that can be connected to the FM-Tco4 HCV / HCV 3G / HCV BT device. With peripherals you can get even more features and extended functionality. All available peripherals can be purchased from Ruptela. Please contact your manager for more details.

Note

Maximum 1-Wire interface power output is 200 mA @ 5 V.

FM-Tco4 HCV / HCV 3G / HCV BT device supports RS232, RS485, 1-wire and CAN interfaces. A list of peripheral devices that can be connected to them:

Available on 1-Wire:

- 4 × Temperature sensors
- 1 × iButton DS1990, DS1971 with passive socket.

Available on DOUTs:

- 1 × ECO Driving panel (Power supply from 1-Wire. 40 mA @ 5 V)
- 1 × Buzzer/LED
- 1 × Ignition lock (including ignition block upon GSM jamming detection)

Available on AINs:

- 2 × Analogue fuel sensors

Available on RS232 ports A and/or B:

- 2 x LLS digital fuel sensors
- 2 x RFID readers
- 1 x TCO driver card reader
- 1 x TK (Only on port B)
- 1 x Spreader
- 1 x Garmin (Send and receive SMS, routes to/from navigation system. (Only on port B)
- Transparent channel
- 1 x Magnetic card reader
- 1 x Weighting system
- 1 x Alcohol sensor
- 1 x TK Touch Print
- 1 x Optitemp, Carrier Vector 1550 support

Available on RS485 port C:

- Up to 10 LLS fuel sensors
- 1 x J1708 interface
- Transparent channel
- J1708 + DTC

Available on CAN interface:

- Vehicle CANbus (FMS) information reading
- HCV CAN
- OBD parameters and diagnostic trouble codes (DTC) reading (depends on vehicle)
- Tachograph reading (including *.DDD file download)
- MobilEye
- DXP CAN
- Trailers
- J1939 + DTC

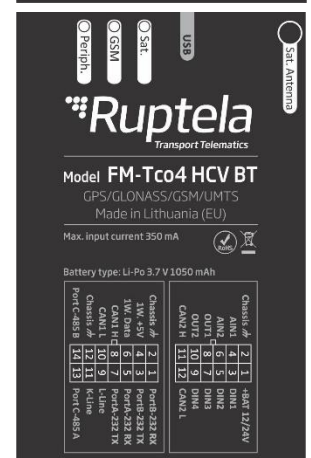
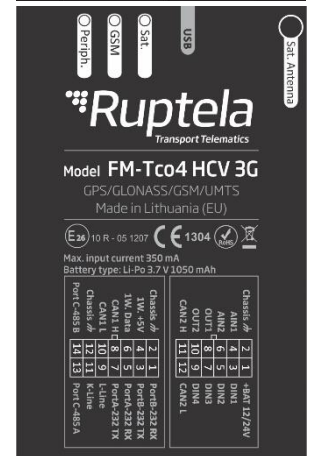
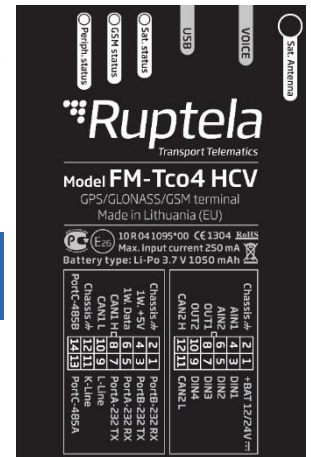

K-line interface:

- OBD parameters and diagnostic trouble codes (DTC) and reading (depends on vehicle)
- TCO driver information reading

1-Wire

- DS1971

Note

- Only FM-Tco4 HCV BT devices have a built in Bluetooth module.

You can find peripheral accessories installation instructions and documentation on our [documentation website](#).

3.7 Certification

FM-Tco4 HCV / HCV 3G / HCV BT devices have passed quality tests and comply with following certifications:

	Certification		
	FM-Tco4 HCV	FM-Tco4 HCV BT	FM-Tco4 HCV 3G
E-mark	✓		✓
CE 1304	✓		✓
RoHS	✓	✓	✓
FCC Part 15			✓

3.8 LED status

3.8.1 GNSS LED

When a GPS/GLONASS signal is not received or it is not accurate, the GPS LED is blinking as follows:

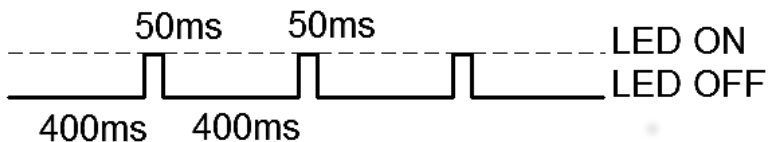

When an accurate GPS/GLONASS signal is received, the GPS LED is blinking as follows:

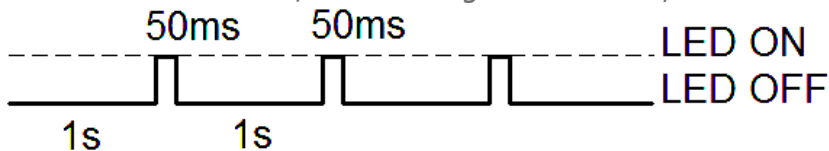

3.8.2 GSM LED

When a GSM signal is not received, GSM LED is blinking as follows:

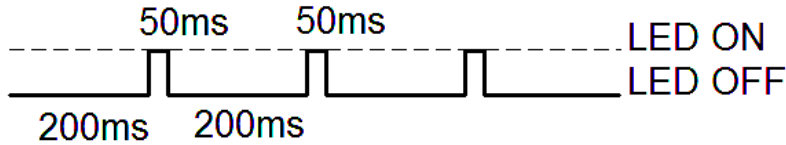

When device has a good GSM signal, but no GPRS, LED is blinking as follows:

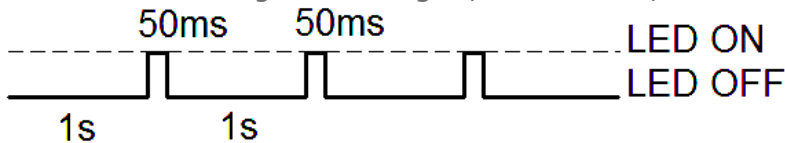

When device has a good GSM signal and it is connected to GPRS, then LED is blinking as follows:

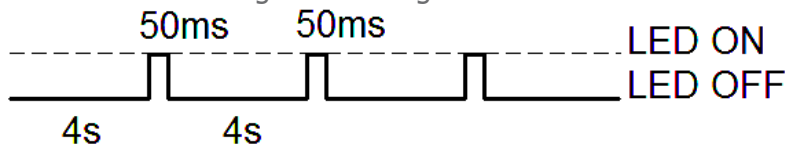

When the device terminal has a GSM signal and it is sending data via GPRS, LED is blinking:

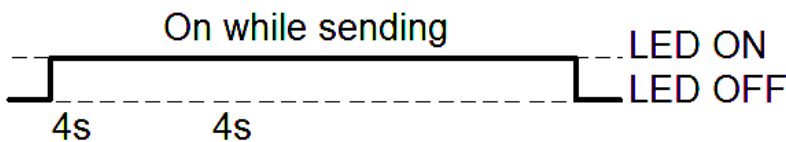

3.8.3 Peripheral LED

The device terminal can have up to 3 peripheral devices attached to it (e.g. CAN, LLS, 1-wire). So there are 4 different types of LED states possible. When there is no peripheral attached, LED will not blink at all:



When there is 1 peripheral interface connected, the peripheral LED is blinking:

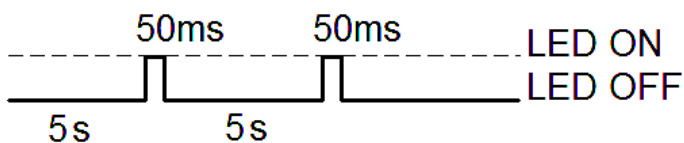

When there are 2 peripheral interfaces connected, the peripheral LED is blinking:

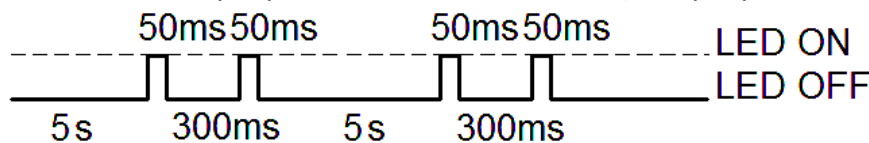

When there are 3 peripheral interfaces connected, the peripheral LED is blinking:

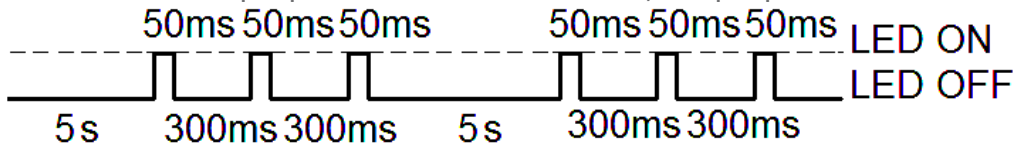

3.8.4 LED status in sleep and deep sleep modes

When device is in sleep / deep sleep mode all three LEDs blink at the same time in the following pattern:

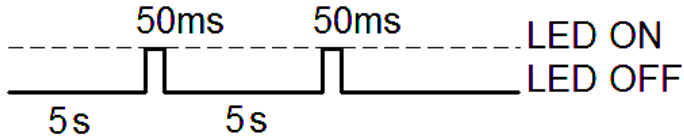

4 Device configuration

4.1 Driver installation

Virtual COM port driver installation is mandatory, only then your PC will recognize the FM-Tco4 HCV / HCV 3G / HCV BT device that was connected to the USB port. You can download newest drivers from our documentation website ([VCOM drivers](#)).

Choose the correct archive file with drivers for your OS version and download it to your PC.

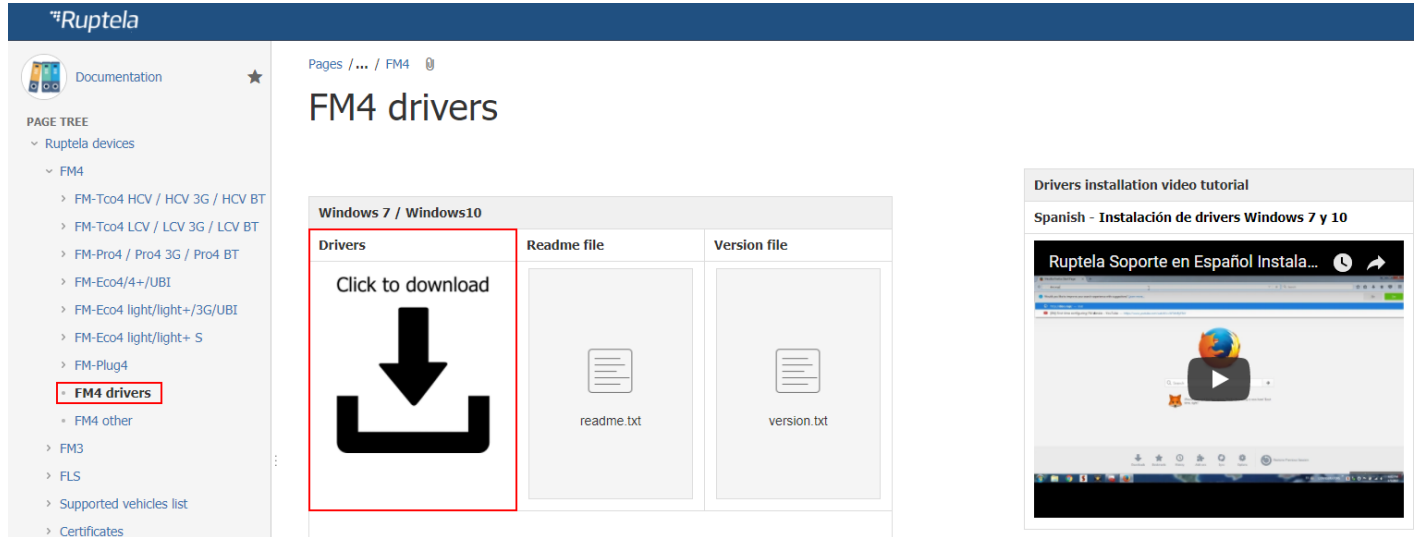

Installation procedure:

- Uninstall any previous Virtual COM port driver versions:
 - Start -> Settings -> Control Panel -> Add or remove programs (Windows 7);
 - Start -> Settings -> Apps -> Apps & features (Windows 10);
- Extract archive file "Win7.zip" or "Win8.zip" to a desired location on your PC.
 - If you are running a 32-bits OS version, launch the "dpinst_x86.exe" [1.]
 - If you are running a 64-bits OS version, launch the "dpinst_amd64.exe" [2.]

Windows 7 Users might get a Security Warning message. Click "Yes" [3.].

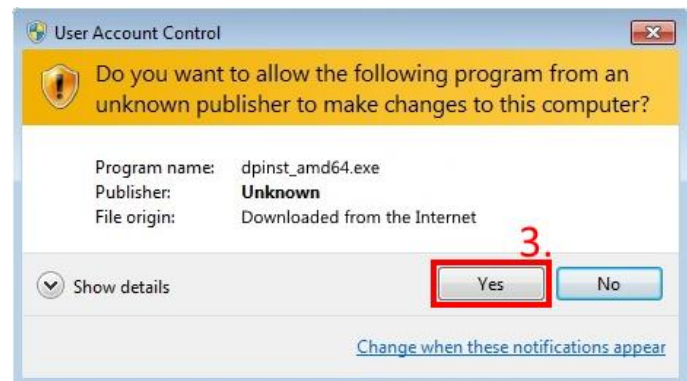

In the next window select "Next" [4.].

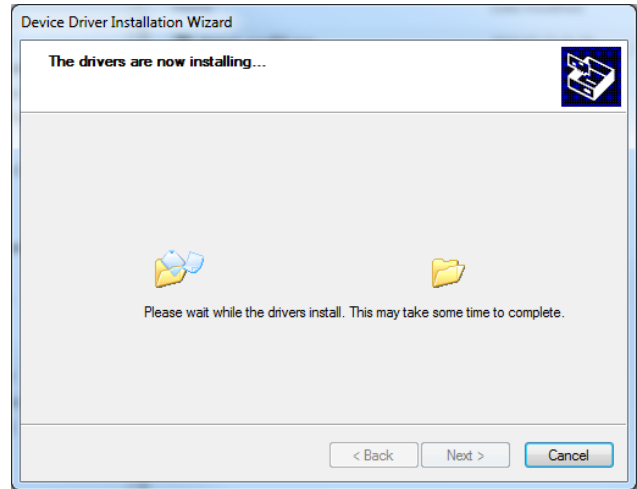
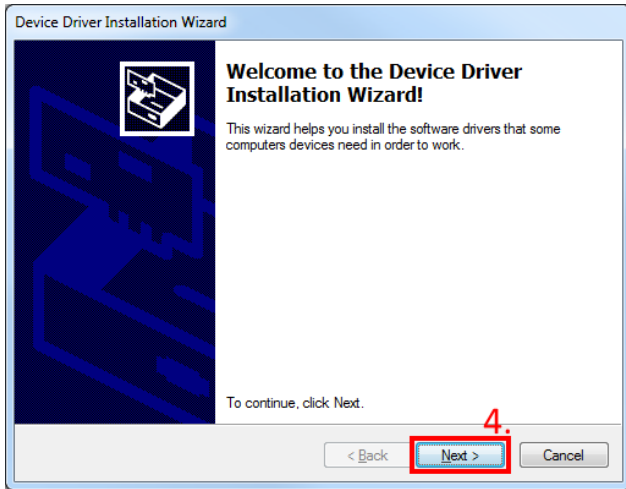

Wait for the setup to complete the installation and click "Finish" [5.].

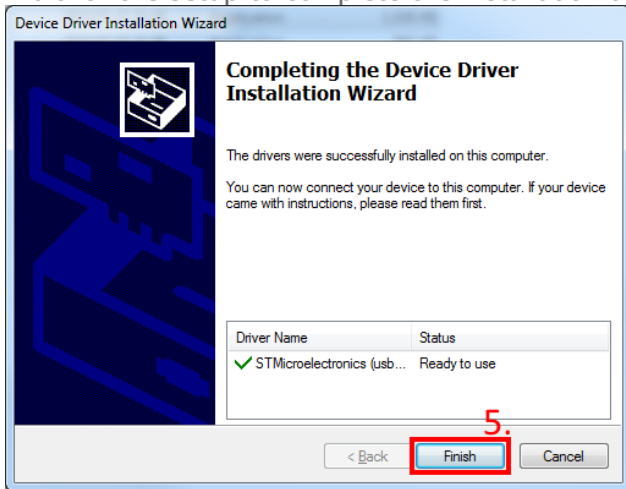

The driver is now installed and ready to use.

4.2 Sample configuration

Please go to our documentation website and download [sample configuration](#) and the latest [configurator](#). Also you will need the latest version of [Microsoft Framework](#).

Operating system requirements:

- MS Windows XP/Vista/7/8/10

Example for FM-Tco4 HCV / HCV 3G:

Start the VCP.exe from configurator folder.

1. Select Tco4 HCV
2. Click **File** → **Open CFG**.
3. In dialog window, browse the sample configuration file you downloaded from the documentation website.
4. Click **Open**.

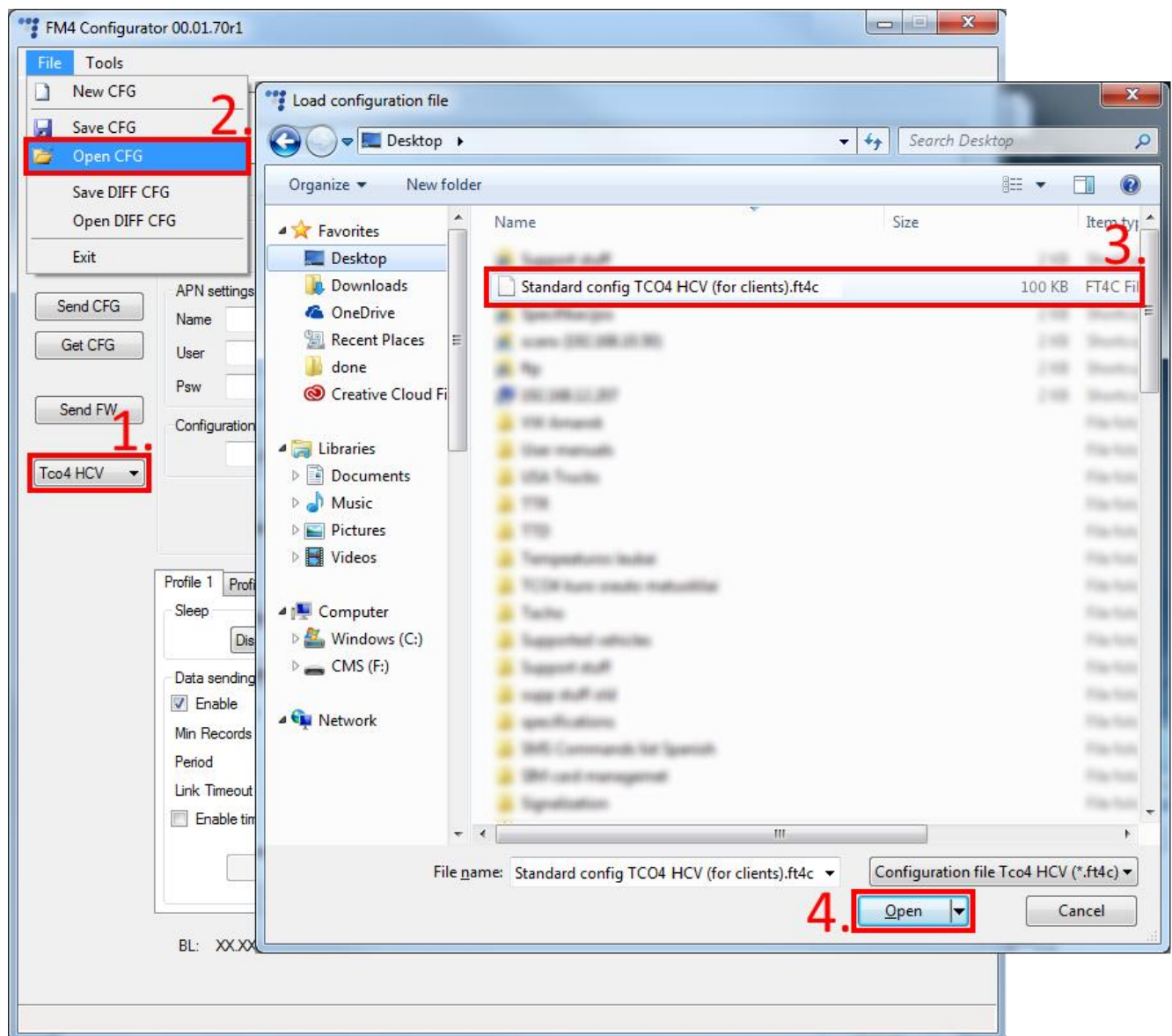

FM-Tco4 HCV BT

Procedure for HCV BT device is very similar. Download configurator and sample configuration file for the FM-Tco4 HCV BT device. In configurator select Tco4 HCV BT and open "Standard config TCO HCV BT (for clients).fg4c" file.

Configuration information

Starting from configurator version 00.03.04.XX, the configurator will display additional information regarding the loaded configuration. The following information will be displayed at the top of the configurator once a configuration is loaded (if no configuration is loaded, the fields will be empty):

1. Configuration source – can be from "Configurator" or from "Device".
 - Configurator – means that the configuration is loaded from the PC;
 - Device [Device_IMEI] – means that the configuration was received from the FM device;
2. FM device FW version – this will be displayed only if the configuration was received from the device;
3. FM4 configurator version – show the configurator version on which the currently loaded configuration was made;
4. Target device – display the FM device model for which this configuration was created or from which device it was downloaded;
5. CFG Tag – is simply additional information that the user can save with the configuration file. Maximum length is 32 symbols, only printable ASCII characters are allowed;
6. Last edited – display the date and time when the configuration was last edited. If the edit was from a PC, the time will be the same as the PC's local time. If the configuration was received from the device, and the device currently has no time from any source, the date and time will be shown as the beginning of this century (2000/01/01 00:00:00);
7. If any changes were made to the currently loaded configuration, a small "*" symbol will appear next to the name of the configuration.

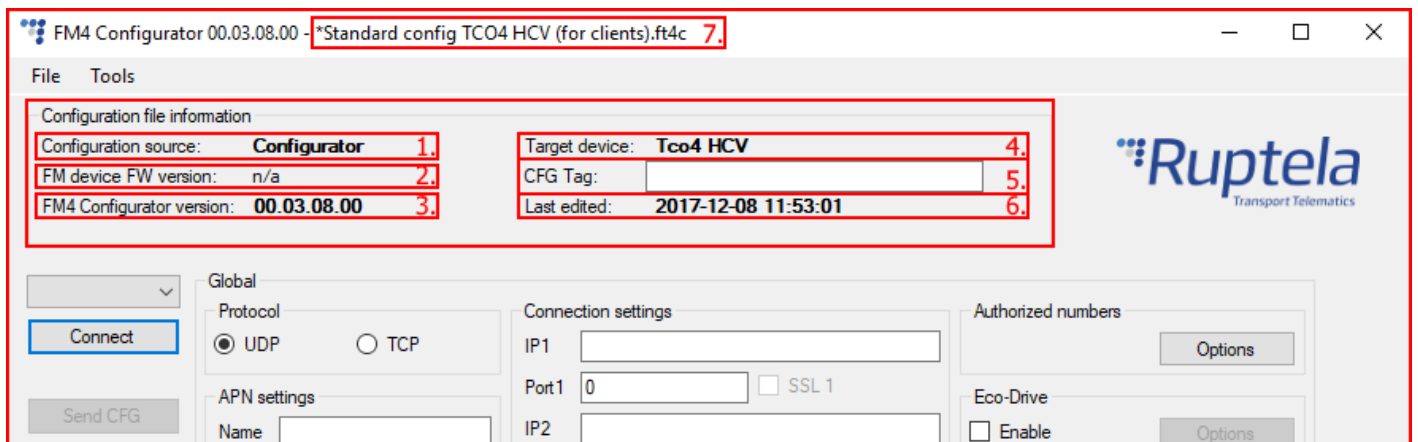

Configuration additional steps

Sample parameters will be loaded. However you will need to enter other parameters on your own.

1. Enter IP (in the 255.255.255.255 format) or a Domain Name (not exceeding 40 characters) and PORT to which the device should send data.
2. Enter APN settings: APN name, User login and Password (if login and password is needed). If you choose to enable **Lock FM device to the SIM card** check-box you will be required to enter SIM

card's PIN code every time you try to connect to the device via USB cable. As long as it is checked you will not be able to use different SIM cards with this device.

3. Select a COM port you connected the device to and click "Connect". At this point the configuration is ready to be send to the device, so the device must be connected to the computer.
4. Click "Send CFG" button. The configuration will be uploaded to the device.

Note

APN name, login and password should be provided by your mobile network operator.

Now the device is configured to send data to the specific server. Sample IO parameters are enabled (loaded with configuration file). You can log in to your tracking platform to see whether the device is sending data.

4.3 Advanced configuration

The configuration tool is quite similar to the ones used for other 3rd generation devices. Overview of the configuration is described in sections.

The **File** menu gives you access to control configuration files. Choose *New/Save/Open CFG* to perform the corresponding action. CFG means full configuration file.

New CFG wizard – It helps users to go through all basic configuration steps.

Generate SMS – This tool allows the user to generate a SMS command to configure the FM device remotely. Working principle and general SMS command functionality is described in the "Device configuration via SMS" document at doc.ruptela.lt

The **Tools** menu contains:

- Language selection options: English or Russian are available.

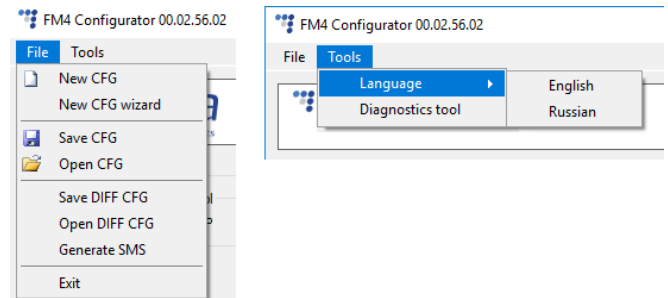

- Diagnostics tool.

Save/Open DIFF allows you to create a DIFF file. DIFF files are used to change only one or few certain parameters without a need to upload the full configuration to the device. It is useful, when updating over-the-air.

Attention

A DIFF file will save all made changes to a configuration. For example changing a number in the IP filed, or marking a checkbox, but, if a change was made, and afterwards reverted to the previous state (checkbox checked, and unchecked afterwards), this will not be marked as a "change made". DIFF will only record changes made to the initial configuration (a loaded pre-set configuration is considered an initial configuration). Particular attention must be taken, when creating a DIFF file, to avoid accidental changes to the configuration.

The control panel on the left hand side allows you to select and control the device.

Select the COM port that the device is connected to and click "Connect". At this point the FM4 configurator checks the compatibility between itself and firmware in the device. Every firmware version is released together with a recommended FM4 configurator. More information about different firmwares and recommended configurators for them can be found in firmware changelogs. After the compatibility check, three outcomes are possible:

1. The firmware and configurator versions are compatible. Go ahead and continue configuring the FM device.
2. The configurator is too old for the current firmware version. An error message will appear. The "Send CFG" and "Get CFG" buttons will be disabled. You will need to download a new version of the configurator, recommended for the firmware version.
3. The firmware is too old for the current configurator version. An error message will appear. The configurator will suggest to update the firmware automatically. To update the firmware, click "Yes". The firmware will be updated to the version supported by the configurator. This can be done without an internet connection.

The image shows a vertical control panel with the following elements from top to bottom: a dropdown menu showing 'COM1', a 'Connect' button, a 'Send CFG' button, a 'Get CFG' button, a 'Send FW' button, and another dropdown menu showing 'Tco4 HCV'.

Note

If the firmware version in the device is older than 00.03.12.XX and you decide to update it, an additional warning window will appear, suggesting you to save your configuration file if you are using the LCV functionality. Click "Yes" to save the configuration file and update the firmware. **Do not forget to send the configuration to the device!** Click "No" to only update the firmware. Click "Cancel" to close the warning window.

Click "No" to close the message without updating the firmware. If the firmware is not updated, the "Send CFG" and "Get CFG" buttons will be disabled. We highly recommend using the latest firmware and configurator.

The "Send CFG" and "Get CFG" buttons are used to send and receive the configuration file to/from the device.

"Send FW" is used to send new firmware to your device manually.

In the drop-down list below you can select the model of the device. If you connected one to your PC, it will be displayed. Now Tco4 HCV should be displayed.

4.3.1 Global settings

The first part of the configuration tool is “Global” settings. Global include connection settings and other settings independent from the profile settings – global settings are the same for all profiles.

The screenshot shows a web-based configuration interface for a device. The 'Global' settings section includes: Protocol (UDP selected), APN settings (Name, User, Psw), Connection settings (IP1, Port1, IP2, Port2, SSL 1, SSL 2, Two servers, SSL client authentication), Authorized numbers, Eco-Drive (checked), Authorized IDs (checked), Audio settings, Configuration Password, GNSS selection (GPS+GLONASS), Geofencing, Driver registration, Towing detection, Impact detection, Send data without GPS fix, and Movement sensor sensitivity (slider set to 8). A red warning message at the bottom states 'Do not use with TrustTrack server!'.

Connection settings – here you should enter server IP and port that the device should connect to. The IP can be entered in the numeric format: 255.255.255.255. You can also use a Domain name (not exceeding 40 characters). IP 2 is a backup IP address, which is used when the device is unable to connect to the first server. **SSL authentication** settings are also configured here, they are described in a separate section.

Note

Please have in mind that ports for TCP and UDP transfer protocols usually are different – please select the correct transfer protocol and enter the correct port.

- **Two servers** – checkbox changes the logic described above. It enables a two servers mode – the same data is repeatedly transmitted to another server with IP2, unless we get a timeout. IP1 is dedicated IP for server, from which we get the ACK's for our record packets sent. After we get the ACK from this IP, record data is considered as successfully transmitted to the server and it is removed from the memory.

In this mode data is sent to IP2 only when connection to the IP1 is established. Packet, which is sent to the IP1 server is also sent to the IP2 server.

Only records are going to be send to the IP2. Data packets such as Transparent Channel, Tachograph, SD card, Garmin will not be sent to the IP2.

Unable to send data:

When unable to establish connection to IP1, device does not connect to the IP2 as well. When connected to IP1 and doing data transmission, but IP2 is unreachable – after receiving ACK from IP1 server, data is removed from memory, which can cause information loss in IP2 server.

Note

Two server mode doubles the amount of data that is being sent. Before using this functionality consider the cost which arises from the higher data traffic.

Protocol sections allows you to choose from two protocols. **UDP** protocol is less reliable than the **TCP**, but also uses less traffic. TCP uses more internet traffic, but it is more reliable. Choose one according to your needs.

Note

If the IP, port or APN fields are greyed out when the device is connected to the configurator, their values cannot be changed.

APN settings are needed for internet connection. These settings must be provided by your mobile network provider. Without APN settings the device will not send any data.

- If you choose to enable the **Lock FM device to the SIM card** check-box you will be required to enter the SIM card's PIN code every time you try to connect to the device via USB cable. As long as it is checked you will not be able to use a different SIM card with this device.

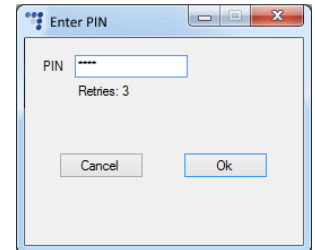

Note

If the "SIM status" checkbox is not enabled, the "Enter PIN" window will not appear when connecting to a FM device. This means you will not be able to access your device.

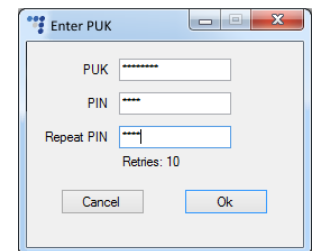

If the wrong PIN is typed in more than three times, the SIM card will be locked.

It can be returned to its original unlocked state by entering a PUK, provided by the service operator after verification. If the wrong PUK is entered ten times in a row, the device will become permanently blocked and unrecoverable, requiring a new SIM card. Once you enter the PUK code, you must set a new PIN.

SIM status section at the bottom of the configuration tool displays SIM card related information. By default the feature is disabled. Tick the checkbox to enable it.

BL: XX.XX FW: XX.XX.XX.XX IMEI: XXXXXXXXXXXXXXXX
 SIM status: -----

Total of seven different statuses are available:

- I. Ready – PIN code is known or PIN code check is disabled. GSM/GPRS modem can operate normally.
- II. Error – Represents a wide range of possible problems. Common reason would be old FW version, which does not support SIM commands.
- III. Unknown – Communication between device and GSM/GPRS modem failed, SIM status is unknown.
- IV. PIN Request – SIM card requests a PIN code, FM device cannot provide it (the code provided by the device is incorrect).
- V. PUK Request – SIM card requests a PUK code.
- VI. Locked – This FM device is attached to a different SIM card.

VII. Not inserted – SIM card is not inserted.

The screenshot displays a configuration menu for a device. A red box highlights the 'Global' section, which includes 'Protocol' (set to UDP), 'APN settings' (Name, User, Psw, and a checkbox for 'Lock FM device to the SIM card'), and 'Connection settings' (IP1, Port1, IP2, Port2, SSL 1, SSL 2, Two servers, and SSL client authentication). Other sections include 'Authorized numbers', 'Eco-Drive' (checked), 'Authorized IDs' (checked), 'Audio settings', 'Movement sensor sensitivity' (slider at 8), 'Configuration Password', 'GNSS' (set to GPS+GLONASS), 'Geofencing', 'Driver registration', 'Send data without GPS fix' (with a red warning: 'Do not use with TrustTrack server!'), 'Towing detection', and 'Impact detection'. Each section has an 'Options' button.

Configuration password allows to lock the configuration – without the password no one can change the device configuration via cable. However, over-the-air update ignores the configuration password.

Driver registration is used to authorize vehicle start, identify driver and account working hours. Full functionality description can be found on our documentation website, [Driver registration](#).

Send data without GPS fix – device cold-start often causes problems because it is not sending data, therefore the user is unable to see parameter values until GPS fix is obtained. This functionality allows data sending even when there is no GPS fix. This feature cannot be used with TrustTrack server! Full functionality description can be found in "Send data without GPS fix" document on our documentation [website](#).

Also, when the device loses GPS fix, there is no way to determine its location. GSM tracking feature can now be used to obtain an approximate location in the densely urbanized areas, where GNSS signal is not available. This feature cannot be used with TrustTrack server! Full functionality description can be found in "Send data without GPS fix" document on our documentation [website](#).

GNSS allows to select positioning network – GPS, GLONASS or GPS+GLONASS. GPS+GLONASS by default (*recommended not to change this*).

Geofencing allows to use internal geozones, configured directly into device. Full description can be found on our documentation website, [Internal geozones](#).

Towing detection – with Towing detection driver can be informed, that his car is being towed. Information about such event is sent to the server, therefore driver might still have time to come back to his vehicle before it is taken away. Full functionality description can be found on our documentation [website](#).

Impact detection – when this feature is active, FM device monitors its acceleration in all directions and generates records, when acceleration exceeds configured limits. Clients can use this feature to get notifications to the server about irresponsible drivers, who hit sidewalks or other obstacles. Full functionality description can be found on our documentation [website](#).

Authorized numbers

- Set a **Password** to restrict access to the SMS commands feature.
- **SMS Alert Number**. When specific I/O parameter is triggered, the FM device will send an alert message to this number.
- **Call Number** – Enter a number which will be called if a specific IO parameter is triggered. This functionality is described in the “Voice calls from IO events” document, available at doc.ruptela.it
- In the **Valid Numbers** table enter specific numbers that will be able to send commands to the device.

Note

The 3G model of the FM device supports an audio interface only in the latest **hardware** version! Older 3G FM devices with an older hardware version will not support voice calls to the FM device.

- If **Enable list for voice calls** is enabled, number entered in the list will be able to make a phone call to the device.
- **Enable configuration over SMS** checkbox controls configuration over the SMS feature. Full functionality description can be found on our [web site](#).

ECO Driving options are used to choose sensitivity for the ECO Drive functionality. It helps to rate drivers according to their safety or according to driver's behaviour. Full functionality description can be found on our web site, [ECO Drive](#).

Authorized ID's allows you to fill in a list of authorized IDs who can start engine when ignition blocking is used. More information about this functionality is available on our documentation website, [FM-Eco4, Pro4, Tco4 + Driver registration](#).

Audio settings allow the user to adjust the following settings:

- Audio output level;
- Microphone gain level;
- Ringtone On\Off.

Movement sensor sensitivity allows you to configure movement sensor according to your needs. If you slide the bar towards the Max, the sensor will detect even very slight movements. If you slide it to the Min, then only stronger movements will be detected.

The screenshot shows a configuration interface with the following sections and highlighted settings:

- Global**: Protocol (UDP selected), APN settings (Name, User, Psw, Lock FM device to the SIM card), Configuration Password, Driver registration (Options), Send data without GPS fix (Options, warning: Do not use with TrustTrack server!).
- Connection settings**: IP1, Port1, IP2, Port2, Two servers, SSL client authentication, SSL settings.
- Authorized numbers**: Options.
- Eco-Drive**: Enable (checked), Options.
- Authorized IDs**: Enable (checked), Options.
- Audio settings**: Options.
- Movement sensor sensitivity**: Slider set to 8 (between 7 and 9), Min, Max.
- GNSS**: GNSS selection: GPS+GLONASS.
- Geofencing**: Options.
- Towing detection**: Options.
- Impact detection**: Options.

Send identification string feature forces FM device to send an identification packet to the server. After that the device waits for the ACK packet from the server. Once device receives this packet, it begins data transfer.

Note

If identification string feature is enabled, you cannot use transparent channel and vice versa.

For more information about this functionality go to our documentation website and look for "[Transparent channel and Identification string](#)" document.

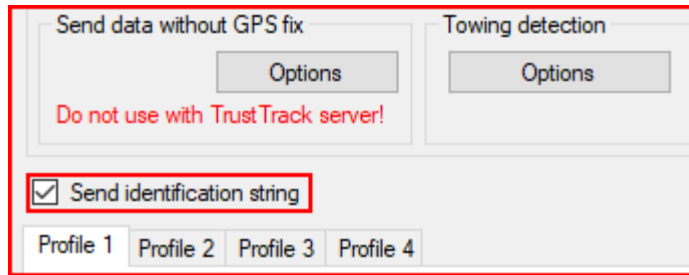

Wireless

Note

Wireless section is available only for FM-Tco4 HCV BT device, which has built in Bluetooth module.

Wireless section contains Bluetooth communication settings. Add a tick to the **Enable** check box to make your FM-Tco4 HCV BT device discoverable by other Bluetooth devices. Click "Options" button to change basic wireless communication settings.

The following fields are currently available in "Wireless Communication" setting window:

- Device Name – Give a name to your FM-Tco4 HCV BT device. Launch "OnTrack Connect" in your smartphone. Go to the Bluetooth devices window. There, among other available Bluetooth devices you should be able to see your device. OnTrack Connect app user manual available [here](#).
- Connection PIN – You need to know this code in order to pair your smartphone with FM-Tco4 HCV BT device. In "OnTrack Connect" choose your unpaired FM device and enter this PIN code.
- Admin Password – You need to know this password in order to connect to the already paired FM-Tco4 HCV BT device. In future it will be used to authorize extensive FM device configuration. For now you can enter anything or just leave this field blank. In the "OnTrack Connect" choose a paired FM device, enter its password and connect to the device.

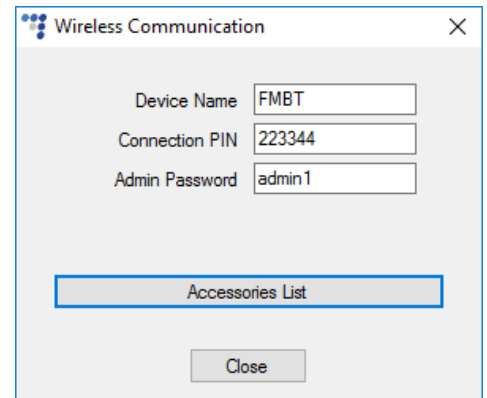

Click the "Accessories list" button. It leads to the "Bluetooth Accessories" window. More information about this feature and specific Bluetooth accessories available on our documentation [web site](#).



4.3.1.1 SSL authentication

SSL (Secure Sockets Layer) is a security technology used for establishing encrypted connections between server and client, as well as authenticating the identity of the server / client. All data transmitted between server and client is encrypted. An **SSL certificate** is required to create an SSL connection. An SSL certificate is a file installed on the server side. An additional certificate can be installed on the client side for extra security. The FM device uses the **TLS v1.2** version of SSL.

Note

Using SSL may increase data consumption and may incur additional costs, according to your data plan.

Note

SSL will **not** work on devices with 3G modems.

SSL can be enabled on each server separately by ticking the **SSL 1 / SSL 2** checkboxes. To do so, the **TCP** protocol must be enabled. The **SSL 1 / SSL 2** checkboxes are disabled by default. After ticking any of the checkboxes, a pop-up warning window will always appear, informing the user that if SSL is enabled without uploading the certificates, the device will remain unprotected. The certificates uploaded for the servers are **Root CA** (certification authority) certificates, meaning that they are issued by a trusted certification authority.

Note

If SSL is enabled and the *ecconnect* or *connect* SMS commands are used, the device will **disable** SSL for that connection and use a regular insecure connection. In order to ensure that no unauthorized device sends SMS commands, it is highly recommended to use the authorized numbers functionality described earlier in this document.

- **SSL client authentication** – this checkbox enables SSL authentication on the client side. The checkbox is disabled by default and can only be ticked when SSL is enabled on at least one of the servers. For the functionality to work, you must upload a client certificate and private key in **SSL settings**.
- **SSL settings** – available only when connected to the FM device. Here you can upload certifications for both server and client to the FM device, as well as the client's private key (necessary for client authentication). The files are uploaded one by one by clicking the **Load** button and selecting the appropriate file in the file browser. **The files cannot be larger than 2025 bytes!** Each file also has *Status* and *CRC* columns for additional information.
 - **Refresh status** – clicking this button will update the status of all files. The status can be one of the following: *Uploaded*, *Empty* or *Unknown*;
 - **Remove all certificates** – clicking this button will delete all certificate and key files stored in the FM device. The status information will be updated automatically.

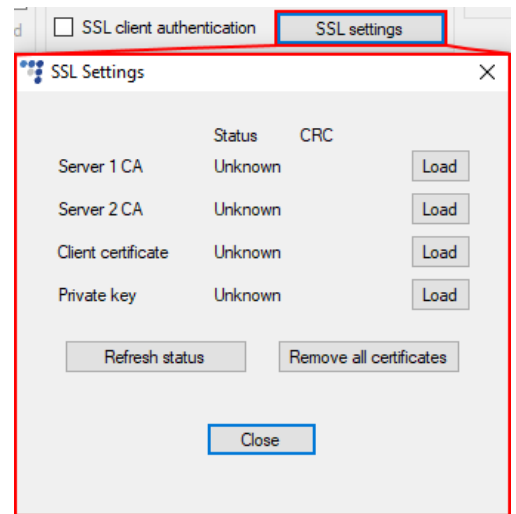

Note

If SSL is configured incorrectly (e.g. the wrong certificates were uploaded), the device will not send any data to the server. The only way to restore data transmission is to reconfigure the device, thus SSL must be configured with caution.

4.3.2 Profile settings

The second part of the configuration tool is for profile settings. This section also contain explanations for other features that needs extensive configuration. Functionalities descriptions are available.

Each "Profile" is a settings set for specific circumstances (e.g. One profile for the vehicle, when it is operated in the native country and another profile, when it is abroad).

Sleep can be *Disabled* or set to *Sleep* or *Deep sleep*. Sleep extends internal battery life by turning off GPS/GSM modems. Deep sleep disables advanced peripherals (1-Wire, CAN1, CAN2, Serial Ports, K-Line). When *Sleep*, *Deep sleep* or *Custom* is selected, it is possible to modify the sleep timeout. Once this time limit is reached, the device will first check if there are any unsent records, if there are no records pending, the device will switch to the configured sleep mode. If there are records pending, the timeout will be twice as long, but it will activate the selected sleep mode non regarding the records in the buffer. By default, timeout is set to 600 seconds.

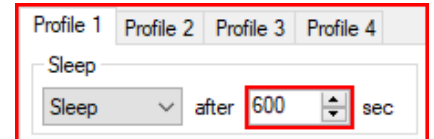

- If engine detection is set to *Always on* – device will not go to sleep;
- If DIN state is High (Value = 1) - device will not go to sleep or deep sleep mode;
- Device cannot go to sleep, if Garmin is connected to it and switched on;
- Any IO events (except those related to switched off peripherals, according to sleep configuration) that are set to generate records on *High* priority will wake up the device.

Conditions for device wake up from sleep mode:

- A High priority event is triggered;
- Configured engine state changes to "ON";
- Sleep timer IO configured time is reached.

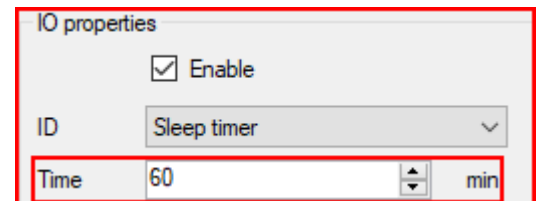

When *Custom* is selected, you can choose, which functionalities should work during device sleep and which functionalities should be disabled. Like previously, it possible to set a time limit. Once this time limit is reached, the device will switch to Custom sleep mode. Full functionality description can be found on our documentation [website](#). (*Feature is not available for Tco4 HCV BT device*).

Data sending settings you can configure the data sending frequency and conditions.

- The **Enable** check box must be enabled.
 - **Min. records** – Minimum number of records required to establish a connection to the server. If the device detects less records than entered value, link to the server will not be opened.
 - **Period** – sets how often the device will check for required number of records.
 - **Link timeout** – this value indicates how long the device should wait before closing the link, after this link was successfully established with the server and all the records had been sent. The default value is 7 seconds, it is recommended not to change it.

- **Link settings** contain the following settings:
 - **Constant link** check box forces the FM device to check server link state and keep it "alive" all the time. If server or network closes the

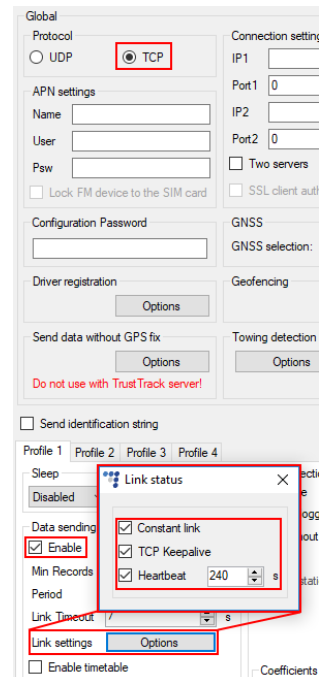

link, the device automatically reopens it but does not send any packets.

- **TCP Keep alive** check box if enabled will send “keep alive packets” every minute if there is no data being sent. Therefore, the device is always accessible via GPRS. **(requires the use of TCP protocol)**
- **Heartbeat** – is a special function that sends a heartbeat packet – GPRS command 16/116 after the set time period has passed **since the last packet sent**. Which means if the device is constantly sending packets, the heartbeat packet will not be sent. As the name explains, this function is used to keep an open socket on the server side if no other packets are sent.

Notes

- If constant TCP link functionality is enabled, the device ignores link timeout parameter for the main connection and uses it only for the emergency connections.
- Constant TCP link and Heartbeat functionalities do not work with the second server if “**Two Servers**” mode is used.

- **Timetable** allows you to select particular days and hours for the data to be sent.

Data collection must be enabled to collect the information.

- **Time without engine** means how often records should be made, when the engine is off.
- The **Engine** drop box allows you to choose how the device will pick up the ignition (consider that the engine is on).
 - *Always on* – No ignition pick up, engine considered always to be on.
 - *Ignition (DIN4)* – Digital input 4 is default DIN used for ignition pick up.
 - *MovSensor* – Detect movement of the vehicle and consider engine to be on.
 - *Custom* – Custom Ignition functionality enables user to select more than one condition to detect engine ignition. Full functionality description can be found on our documentation [website](#).

- **GPS stationary navigation filtering** eliminates GPS jumps, when the vehicle is not moving.
- **Coefficients** are used to collect records in addition to the engine on/off parameters. They help to get a more accurate route of the vehicle. A record will be made when:
 - **Distance** that was set - has been achieved.
 - **Time with engine** has passed.
 - **Radial** turn of degrees that was entered - has been detected.

Note

Keep in mind that FM Device is not designed to have a perfectly accurate time tracking function. Due to various reasons minimal deviations are possible. Over prolonged time periods these small deviations might add up and produce time tracking inaccuracies. Few examples:

- Device is configured to track one event for 1h. However actual event tracking might last for 1h ± Error (i.e. 5 seconds).
- Device is configured to gather records every second. Depending on the device's state, record gathering time might deviate and last longer (i.e. 2, 3 or even 5 seconds).

The screenshot shows the configuration interface for Profile 1. The 'Data collection' section is highlighted with a red box and contains the following settings:

- Enable:**
- SD card logging interval:** 0 s
- Time without engine:** 60 s
- Engine:** Always on
- GPS stationary navigation filtering:**

Below the 'Data collection' section is the 'Coefficients' section with the following settings:

- Distance:** 1000 m
- Time with engine:** 60 s
- Radial:** 60 deg

Other visible settings include 'Sleep' (Disabled after 600 sec), 'Data sending' (Enabled, Min Records: 1, Period: 60 s, Link Timeout: 7 s), and '2G - 3G' (Auto).

2G – 3G section allows to set device operation mode either to 2G or to 3G. This feature is supported in FM4 devices that have UG96 GSM modem. Three different operation modes can be set:

- **Auto** – Default option. FM device uses 3G when it is available. If for some reason 3G is unavailable or it becomes unavailable during operation, the device automatically switches to GSM/GPRS (2G mode). Once 3G is available again, it will switch back to 3G mode automatically.
- **GSM only** – Device operates only in 2G mode.
- **UMTS only** – Device operates only in 3G mode.

Note

- FM-Tco4 HCV devices with hardware versions that do not have UG96 modem operate only in 2G mode. For these devices "Auto", "GSM only" and "UMTS only" options have no effect.

- Almost all functionalities that are available in FM-Tco4 HCV devices are also available in FM-Tco4 HCV 3G. Among previously mentioned exceptions, this device also does not support modem firmware update over the air.

The screenshot shows a configuration window for Profile 1. It includes sections for Sleep, Data sending, Data collection, and Coefficients. The '2G - 3G' dropdown menu is highlighted with a red box and set to 'Auto'. Other settings include 'Sleep' set to 'Disabled' after 600 seconds, 'Data sending' with 'Enable' checked and 'Min Records' set to 1, 'Data collection' with 'Enable' checked and 'Time without engine' set to 60 seconds, and 'Coefficients' with 'Distance' set to 1000 meters, 'Time with engine' set to 60 seconds, and 'Radial' set to 60 degrees.

Operator list

- **1st... 3rd Profile** tab – operators list in this tab allows selection of operators used in current profile. If operator that is in the list was not found, then device will search for other operator in the list. If no operators were found, device will switch to the next profile.
- **Blacklist** has opposite meaning for operator list. Operators that are in blacklist will not joined.
- **Enable priority in list** - search for operators according to number in list. If it is not selected, device will search for operator randomly.

Note

Black list is one for all profiles but operator lists are different for each profile.

- **GPRS Attempt** – how many times device will try to attach to operator`s GPRS before trying another operator.
- **GPRS data counter** – how many kilobytes of data device should send before performing next operator search.
- **Temporary blacklist** – temporal ban period in seconds. Sometimes when the FM device connects to the operator with unavailable GPRS, the device is connected, but cannot transmit any data to the server. In such case temporary blacklist is used. Operator with unavailable GPRS gets into the temporary blacklist, which prevents the FM device`s connection to this operator on the next operator search.

In other case, device connects to mobile operator and successfully obtains GSM and GPRS signal. However, records still do not reach the server. Device has an ability to work around the faulty network (i.e. when network connection is lost) by putting this operator into the temporary blacklist. Ban in this case is implemented via 2nd level temporary black list logic. Network verification is done as follows:

- Server pinging – device performs server pinging only when there is no response (no ACK) from the server and if the connection to server is not available.

It will make up to 3 separate pinging attempts. If any of these attempts are successful, network will be verified. In an ideal case, server responds after the first attempt, network is verified and no more pinging operations are needed.

If the server fails to respond to all of them, the device will switch to another operator, after putting current operator into the temporary black list.

During a single pinging operation device transmits approximately 256 bytes of data. If device needs to make all three attempts, it will send approximately 768 bytes.

- Operator is also added to the temporary black list, when the device receives "13110" error code from the operator. According to Quectel M95 AT command manual the first number in error code "1" stands for "Cause for protocol stack (PS) layer" and the rest "3110" stands for "Network fail".

Received trouble codes can be monitored with the help of "GSM trouble codes" IO parameter.

Note

This functionality might be compatible and might be supported with 3G modems used in Ruptela's FM devices.

Key point about the temporary black list:

- Ban period is configurable. When all operators get into the ban list, ban list is cleared.
- Banned means that the terminal was not able to get the GPRS context, it was unable to connect to the operator, server failed to respond to 3 consecutive ping requests or that the terminal received "3110" error code from the mobile operator.
- Ban list is in the RAM the memory, it is cleared after reset or power off.

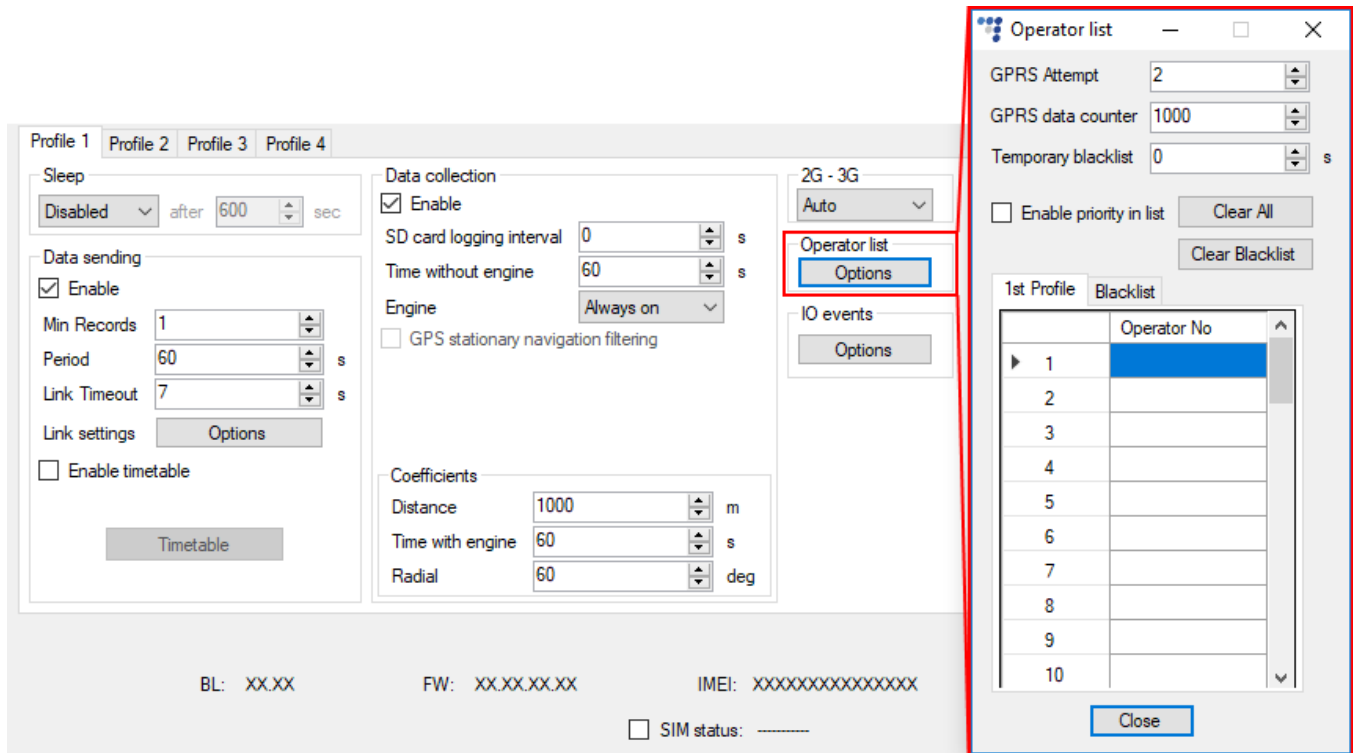

4.3.3 IO settings

IO events "Options" button opens up a new "IO settings" window, here you can enable or disable IO parameters that will be sent to a server. The setting the user should configure, is the protocol selection. **Protocol selection** section has a checkbox, where you can choose to "Send I/O data with v1.1 protocol".

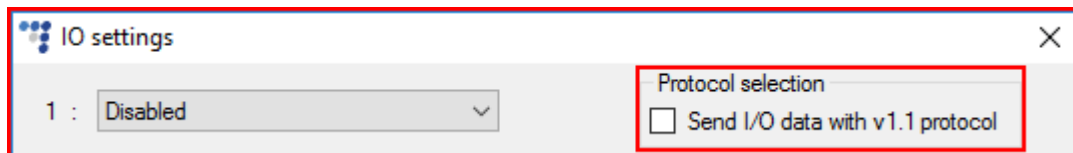

Note

A significant part of the IO parameters require that the protocol v1.1 is enabled! Without it enabled, these parameters will not be displayed in the ID list. Enabling the protocol will delete all unsent records from the device.

After the user decided on the protocol settings in accordance with his needs, he can move on to the IO parameters. There are several ways to enable IO parameters, the first way described is the fully manual way, where the user enables and configures each IO by hand:

1. You have 80 slots for parameters. Select a slot that you want to enable.
2. In the **IO properties** section tick the **Enable** check box, otherwise the slot will remain empty.
3. **ID** contains the parameter list. Choose a parameter you want to enable for the selected slot. One parameter can be enabled only one time.
4. **Level** is used with hysteresis mode, *see 7.c below for more details.*
5. **Delta** is used with hysteresis mode, *see 7.c below for more details.*
6. **Average**. Some parameter`s values change rapidly and do not correspond any valuable information. Averaging values for some period of time gives a more usable value of the parameter (e.g. fuel level

often oscillates. Averaging gives you an approximated value that correspond to the real fuel level in the tank).

7. **Event on** – describes how the parameter will be measured and sent:
 - a. "Monitoring" – The parameter value is always monitored and sent with every record.
 - b. "Change" – when the value changes, a record will be made regarding this change. However, the parameter is monitored and sent to the server with every record.
 - c. "Hysteresis" – The record is generated because of the specified change in the parameter value. E.g. parameter is a "Power supply voltage". Level sets a point of reference, in this case 12700 mV. Delta is a variation in the value, e.g. 1000 mV. The record will be generated (because of the parameter value change), when a Power supply voltage drops to < 11700 mV and/or > 13700 mV. You can select the condition "on rising" or "on falling".
8. Select **Include data only on event** to get a parameter value only when the condition (set in step 7) is met. In other cases the parameter value will not be included in the records.
9. If **Priority** is set to "High", the record will be sent immediately, disregarding data sending settings. If it is "Low", the device will wait for suitable conditions to open a link to server.
10. Upon an event of a value change in some parameter you can configure the device to **Switch to** the other profile.

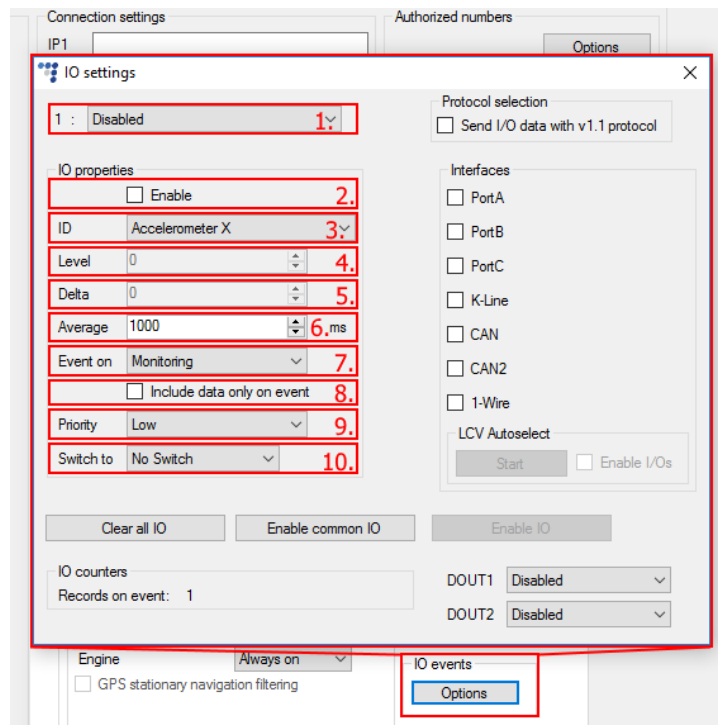

Note

Some IOs will have a "Debounce" setting instead of the "Average" setting. Debounce defines for how long the device must receive a changed state of an IO, before it registers the changed state. For example, the DIN state changed from 0 to 1 and Debounce is set to 5000ms, so the signal from the DIN must remain constant for the period of 5000ms to actually change the state of the IO from 0 to 1.

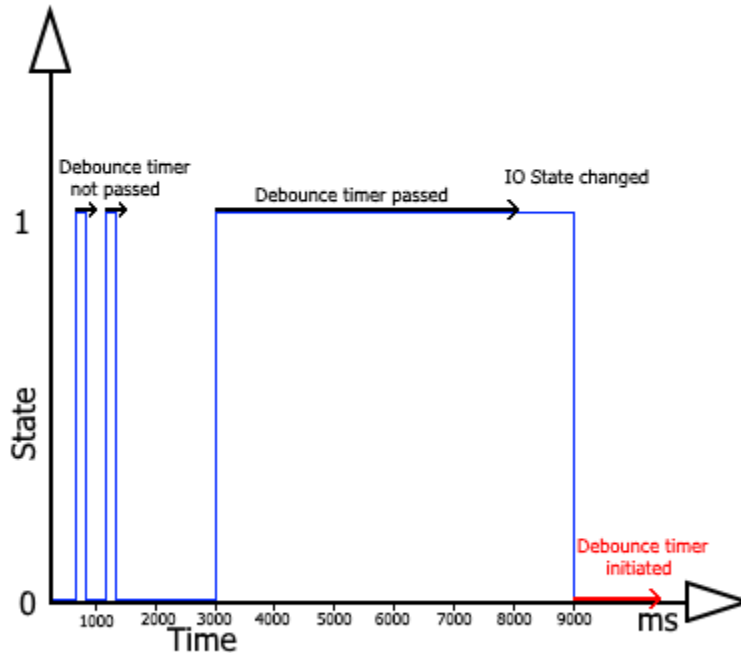

If IOs were configured incorrectly, or the user simply decides to re-do the configuration, he can use the “Clear all IO” button, which disables all the enabled IOs along with their configuration in the selected profile.

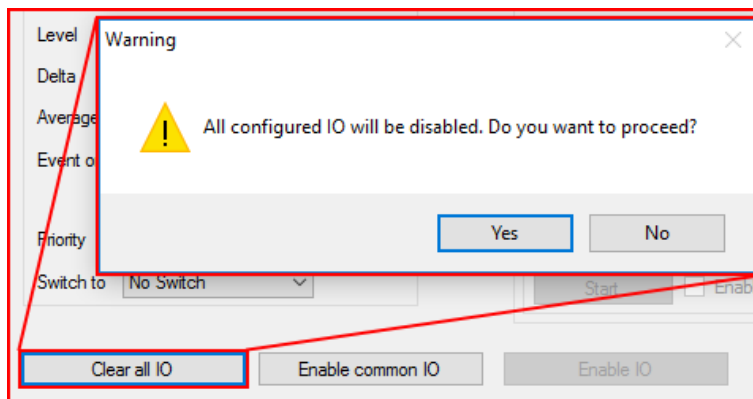

The next method describes how to automatically enable and configure commonly used IOs. To do this, the user must simply click the “Enable common IO” button. This will open a window with a list of IO parameters that will be enabled along with additional information, such as:

- Free IO slots remaining after the selected IOs are enabled;
- Amount of IO parameters selected.

The user can also choose, which of the IO parameters to enable, this can be done by unchecking the checkbox before the IO parameter name. To enable the selected parameters, the user must click “Save”.

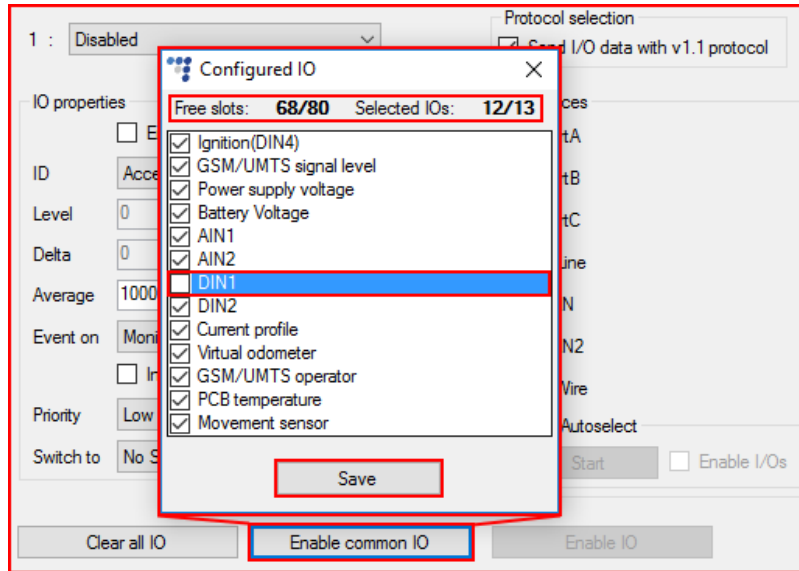

If there are not enough slots to enable the selected IO parameters, an error window will appear.

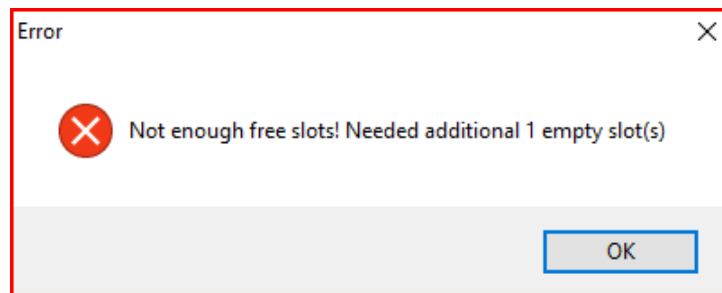

Lastly, the "Enable IO" button enables IOs for the selected interfaces. **This button is available only if the "Protocol v1.1" is enabled!**

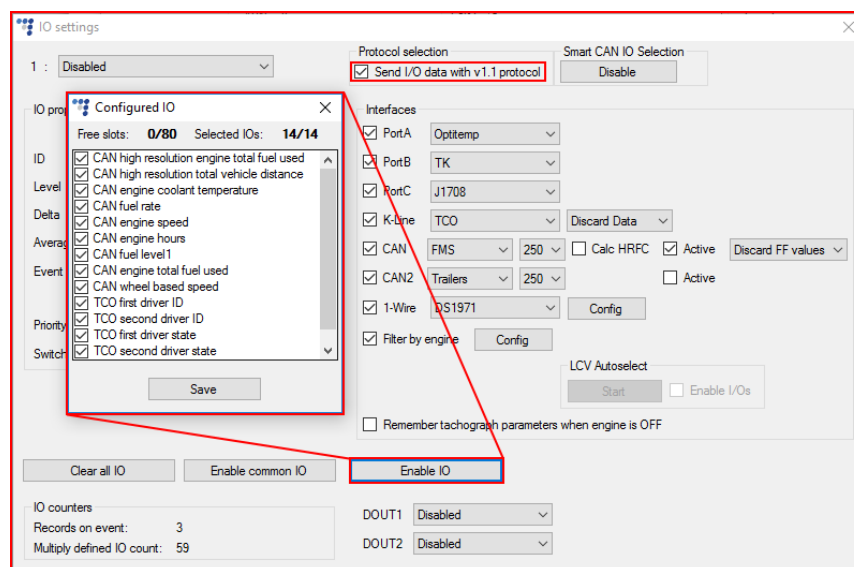

4.3.3.1 SMS Alerts and Custom SMS Alerts

Some of the enabled IO parameters after the main configuration will have an option to enable SMS alert. SMS alerts will be sent to the previously configured number in section 4.3.1 "Global settings". This functionality is available only for the IO parameters described further on. Additionally to sending a SMS alert, the user can customize the SMS message. The list of IO parameters and their mandatory configuration is provided further on:

- DIN1 – Event on "Change", custom SMS alert on DIN status High & Low;
- DIN2 – Event on "Change", custom SMS alert on DIN status High & Low;
- DIN3 – Event on "Change", custom SMS alert on DIN status High & Low;
- Ignition (DIN4) – Event on "Change", custom SMS alert on DIN status High & Low;
- Power supply voltage – Event on "Hysteresis" on Falling or on Both;
- GPS speed – Event or "Hysteresis" on Rising or on Both.

Examples for the custom SMS fields are shown below:

The image shows three examples of the 'IO properties' configuration window. Each window has a red border around the 'SMS Alert' section at the bottom. The first window is for 'DIN1' with 'Event on' set to 'Change'. The second is for 'GPS speed' with 'Event on' set to 'Hysteresis' and radio buttons for 'On Both', 'On Rising', and 'On Falling'. The third is for 'Power supply voltage' with 'Event on' set to 'Hysteresis' and radio buttons for 'On Both', 'On Rising', and 'On Falling'. Each window includes fields for 'SMS alert text' for 'Event on high' and 'Event on low'.

Standard rules for SMS alerts apply, described in "SMS command list" available at doc.ruptela.it section 1.2.2 "SMS alerts with date & time". The maximum custom SMS text length is 50 symbols.

Note

Only GSM 03.38 symbols can be used in the custom SMS text.

4.3.3.2 Interfaces

Interfaces section gives ability to enable or disable all of the device's interfaces. Different interface modes and devices that can be connected to them are listed in 3.6 paragraph.

The image shows a screenshot of the configuration interface. On the left, the 'IO properties' section is visible with 'Enable' checked, 'ID' set to 'Accelerometer X', and 'Level' set to 0. On the right, the 'Interfaces' section is highlighted with a red border and contains three checkboxes: 'PortA', 'PortB', and 'PortC', all of which are currently unchecked.

- **Port A** – RS232 PortA.

- **Port B** – RS232 PortB.
- **Port C** – RS485 PortC.
 - *J1708* - for vehicle J1708 information reading.
 - *Transparent channel*
 - *J1708 + DTC* - for diagnostic trouble codes (DTC) reading from J1708 data line.

More information and connection instructions available at our documentation [website](#).

Bellow you will find checkboxes for the K-Line, CAN and CAN2 interfaces.

K-Line – if you put a tick in the K-Line checkbox, then a dropdown list appears, where you can choose:

- *OBD* – for OBD parameters and diagnostic trouble codes (DTC) and reading.

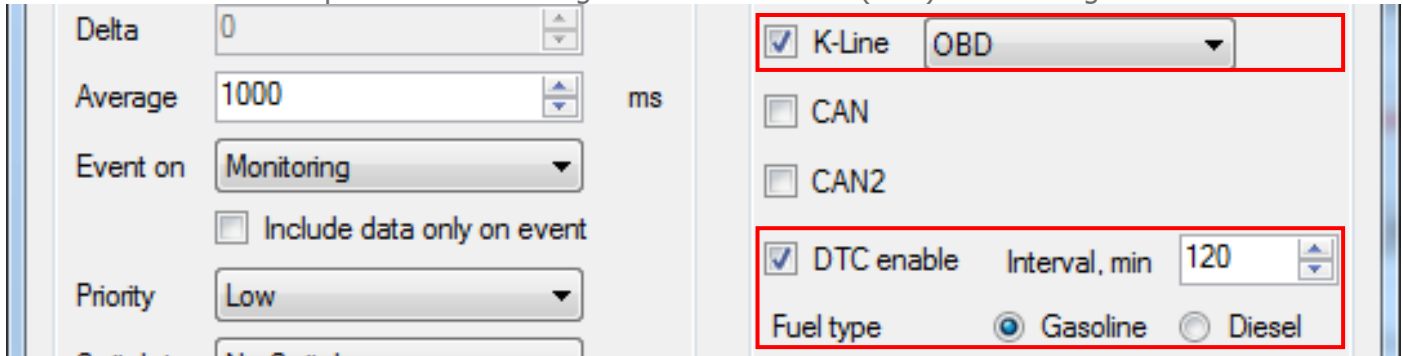

- *TCO* – for TCO driver information reading.
 - *Discard data* – default option. If data packets from the tachograph have invalid CRC values, the device will discard these packets. In this case, new records contain previously obtained K-Line information (from data packets that had a good CRC value).
 - *Put FF values* - if data packets from the tachograph have invalid CRC values, the device will put FF values in the records.

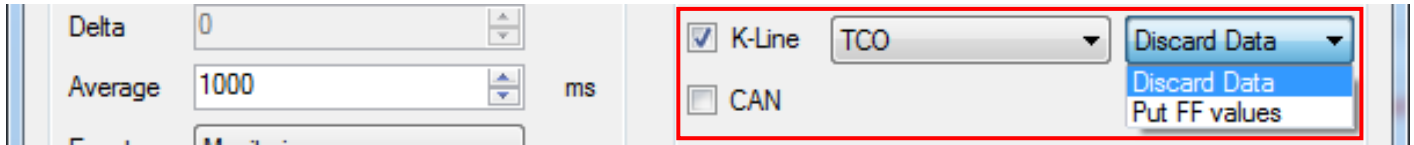

- *Tacho read* – for Tachograph reading (including *.DDD file download).

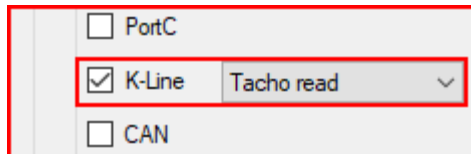

CAN – if you put a tick in the 1st CAN interface checkbox, then a dropdown list appears, where you can choose one of the following:

- *FMS* – for vehicle CANbus (FMS) information reading.
- *OBD* – for OBD parameters and diagnostic trouble codes (DTC) and reading.
- *MobilEye* – for communication with MobilEye device.
- **LCV – Not recommended for FM HCV devices.**
- *HCV* – for HCV CAN (heavy commercial vehicles) information reading.
- *DXP CAN* – DXP electric vehicle information reading.
- *Tacho read* – for Tachograph reading (including *.DDD file download).

- *Trailers* – reading trailer CAN parameters form WEBCO system.
- *J1939 + DTC* – for diagnostic trouble codes (DTC) reading from J1939 data line.

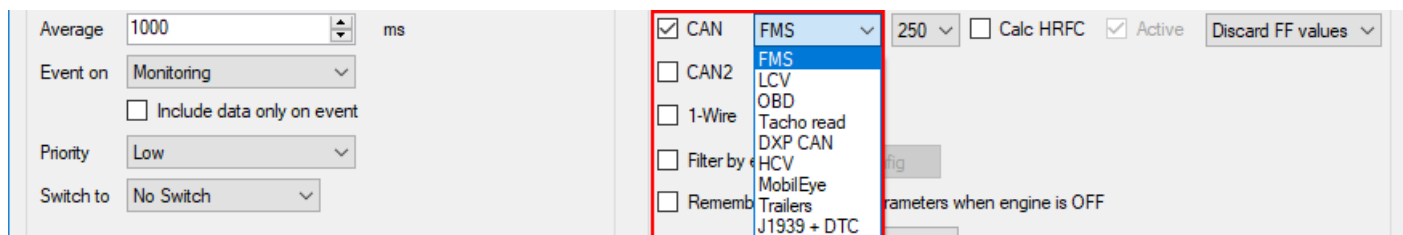

CAN2 – 2nd CAN interface checkbox has all the same options as CAN interface described above.

Note

Both CAN interfaces are working at the same time. If you physically connected to the 1st CAN interface, you have to configure 1st interface accordingly. Same goes for CAN2.

Additional fields can be used in conjunction with CAN interfaces. This depends on interface configuration.

Smart CAN IO selection

“Smart CAN IO Select” functionality allows to add CAN IO parameters only when *FMS*, *LCV*, *HCV* or *DXP CAN* mode is enabled on the CAN interface. When other modes are set, CAN IO parameters are hidden. Smart select is mostly meant for the CAN *LCV* mode. By default Smart CAN IO Selection is always on. First we will describe these CAN modes. After that, there will be a section explaining how to turn Smart CAN IO Selection off and why it could be useful.

Something to consider, when Smart CAN IO Selection turned on:

Enabling/disabling CAN interface might cause some issues. Let’s say Smart CAN IO Selection is on. One of the CAN interfaces is enabled and *FMS* or *LCV* mode is selected in the drop down menu. Some CAN parameters (*CAN engine speed*, *CAN wheel based speed etc.*) are added to the IO list. If you decide to disable this CAN interface, some of the CAN IO parameters will be disabled as well. You will be warned about this with a new pop up window.

Similarly, if you change CAN *FMS*, *LCV*, *HCV* or *DXP CAN* mode to something else, the CAN IO parameters will be disabled.

CAN LCV:

Note

It is not recommended to use CAN LCV on FM-Tco4 HCV devices.

CAN HCV:

CAN HCV mode is used with a specific set of Heavy Commercial Vehicles.

Autobaud – If this checkbox is enabled, device will automatically determine a correct baud rate that should be used, while receiving data from vehicle’s onboard computer.

Active – If this checkbox is enabled, device will do both, receive and send data to the vehicle’s onboard computer.

HCV Group selection, HCV Sub group selection, ? and Channel buttons.

- Smart CAN IO Selection with the CAN HCV mode.

Average 1000 ms
Event on Monitoring
Include data only on event
Priority Low
Switch to No Switch
CAN HCV Calc HRFC Autobaud Active Discard FF values
CAN2
1-Wire
Filter by engine Config
LVC Configuration
Truck ? Truck2

Calc HRFC - enables fuel consumption recalculation from fuel rate for HCV CANbus mode. Recalculation works only when high resolution fuel consumption data from CANbus is not available.

FMS data filters drop down menu. It is used to set a HCV data filter – this function is described in the next section “**CAN FMS**”.

Filter by engine

This feature allows to filter CANbus data by engine state. It helps to solve errors in EcoDrive data calculations, which arise from invalid CANbus data. Errors occur, while vehicle’s ignition is being turned off and during a short time period, after it was turned on. Full feature description is provided in the “[CANbus filter by engine](#)” document.

CAN FMS:

Note

It is possible to configure FMS on one CAN interface and OBD on the other. OBD configuration is described further in the document. If FMS+OBD is configured it is important that the OBD interface works properly! If the OBD is not receiving information (no communication), then the FMS interface will not work as well.

Baud rate - two possible options are available in the FMS Baud rate dropdown list: 250, 500. Data transfers rate depends on vehicle.

Average 1000 ms
Event on Monitoring
CAN FMS 250 Calc HRFC Active Discard FF values
CAN2

Calc HRLFC - enables fuel consumption recalculation from fuel rate for FMS CANbus mode. Recalculation works only when high resolution fuel consumption data from CANbus is not available.

Average 1000 ms
Event on Monitoring
CAN FMS 250 Calc HRFC Active Discard FF values

Active – If this checkbox is enabled, device will do both, receive and send data to the vehicle’s onboard computer.

Average 1000 ms
Event on Monitoring
CAN FMS 250 Calc HRFC Active Discard FF values

FMS data filters drop down menu. It is used to set FMS data filter:

- *Discard FF values* - default option. Device sends only valid data (according to SAE J1939 standard) to server. It discards FMS data packets with FF values. In this case, new records contain previously obtained FMS parameter values (from valid data packets).

Note

Filter is applied only to the following FMS parameters: *Engine total fuel used, High resolution total fuel used, Engine speed, Wheel based speed, Trailer weight, Cargo weight.*

- *No filters* – Device sends all data to the server.

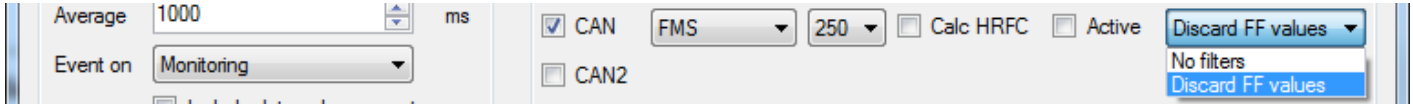

Filter by engine

This feature allows to filter CANbus data by engine state. It helps to solve errors in EcoDrive data calculations, which arise from invalid CANbus data. Errors occur, while vehicle's ignition is being turned off and during a short time period, after it was turned on. Full feature description is provided in the "[CANbus filter by engine](#)" document.

Remember tachograph parameters when engine is OFF

Problems might arise with driver working time calculations, when FMS gateway and digital tachograph switches to sleep mode and are not providing driver ID, working state and other driver related information.

When enabled, this functionality allows FM device to keep last known driver related I/O parameter values, when the engine is OFF and there is no communication with the digital tachograph.

Feature affects the following I/O parameter values:

TCO first driver ID 1, TCO first driver ID 2, TCO second driver ID 1, TCO second driver ID 2, TCO first driver state, TCO second driver state, TCO first driver card, TCO second driver card.

Note

In certain cases this feature might cause errors in "Time analysis" calculations. I.e. when driver changes his status or removes the card from tachograph, while engine is OFF and there is no communication with digital tachograph. In that case device would provide wrong data in mentioned IO elements.

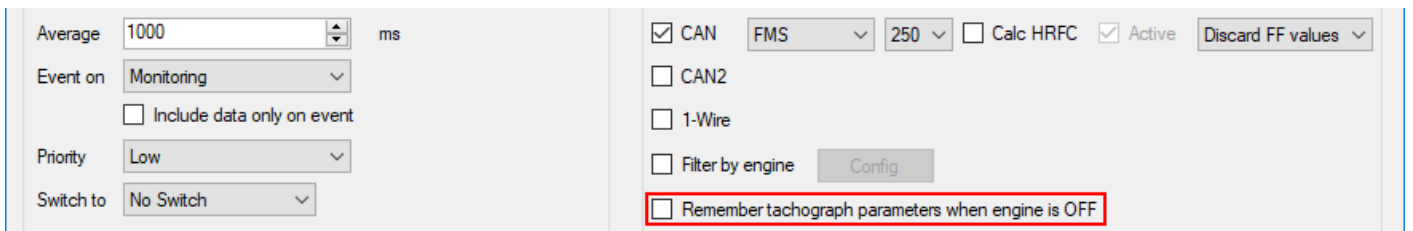

Tacho read:

This mode is used to read tachograph data, through the CAN line which is directly connected to the tachograph port C. Drop down menu on the right controls data exchange rate between FM device and tachograph. More information available in the "[FM-Tco4 HCV Ruptela Tachograph Solution](#)" document.

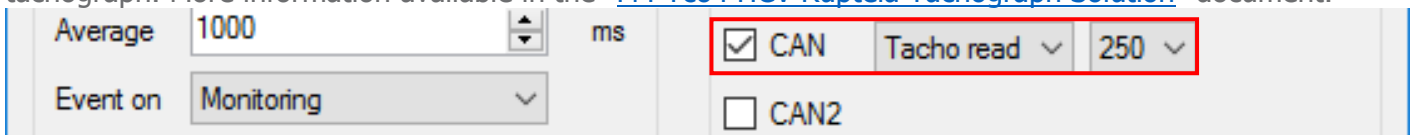

Remember tachograph parameters when engine is OFF check box functions the same way as described in the CAN FMS section.

DXP CAN:

This mode can be used to read CANbus information from electric DXP vehicles.

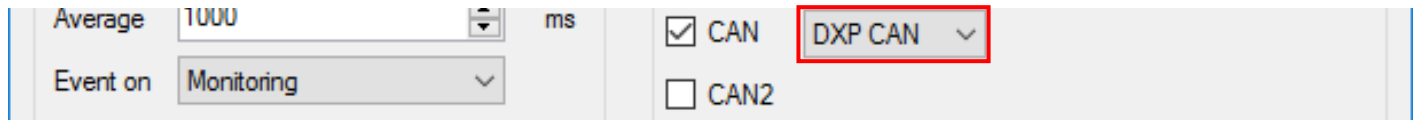

Disable Smart CAN IO Selection

The section itself and the "Disable" button will be visible only when one of the CAN interfaces is enabled and *FMS*, *LCV*, *HCV* or *DXP CAN* mode is selected. Also, when Port C is enabled and the *J1708* mode is selected. With other modes, both are hidden.

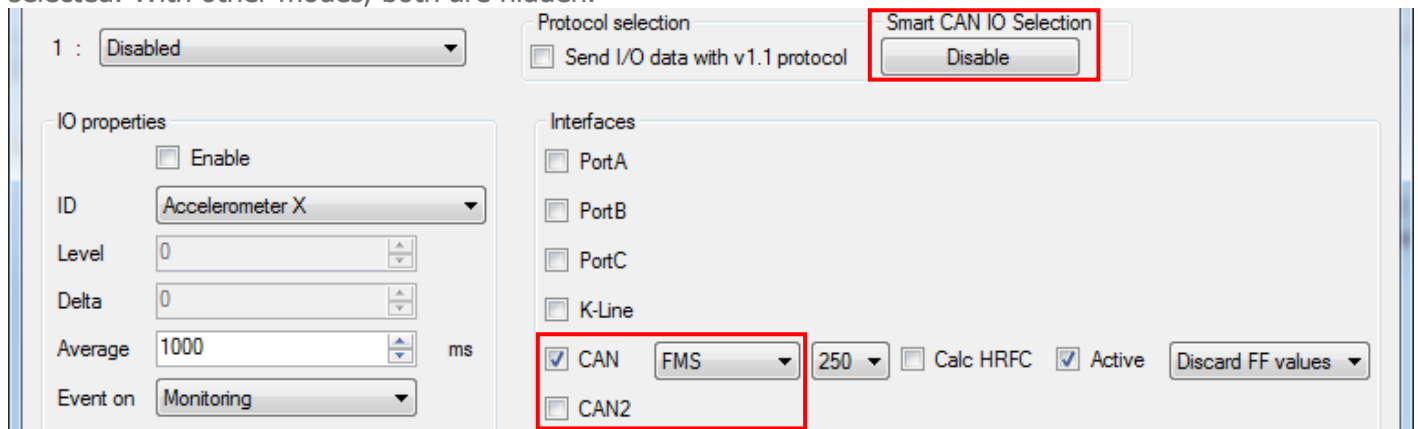

Click the "Disable" button to turn the Smart CAN IO Selection off. Button will be dimmed. To turn this feature back on, close the "IO Settings" window and restart the configurator. Smart CAN IO Selection functionality will go back to its default ON state.

Use Smart CAN IO Selection "Disable" button, when you need to switch from one CAN interface to another, without losing enabled CAN IO parameters. Don't forget to set the same configuration

(Example: You have configured CAN FMS 250 Active on the 1st CAN interface. You have enabled few CAN IO parameters. Now you want to switch to the 2nd CAN interface without losing those parameters. Click "Disable" button in Smart CAN IO Selection section. Disable 1st CAN interface or set different mode. Enable 2nd CAN and set FMS 250 Active. Switch is complete.

Similarly, you could transfer CAN IO parameters for LCV mode. Same Group, Subgroup combinations has to be used on both interfaces. For example, switching from 1st CAN LCV VAG-VAG1 to 2nd CAN LCV VAG-VAG1 is allowed.

Switching form FMS to LCV or from LCV GroupX, SubgroupX to LCV GroupY, SubgroupY is not recommended. Some CAN IO parameters eventually would be lost.)

CAN OBD:

DTC enable - here you can specify Diagnostic Trouble Codes reading interval in minutes. Below two additional checkboxes are displayed, meant to specify **Fuel type**: "Gasoline", "Diesel".

Average 1000 ms
Event on Monitoring
 Include data only on event
Priority Low
 CAN OBD
 CAN2
 DTC enable Interval, min 120
Fuel type Gasoline Diesel

CAN J1939 + DTC:

Not only OBD interface can be used to read diagnostic trouble codes. They can also be read from J1939 and J1708/J1587 (PortC J1708 + DTC) data lines. When one of supported DTC source is enabled, FM device will listen for specific packets with the DTC codes and attach them to the DTC delivery mechanism.

Average 1000 ms
Event on Monitoring
 CAN
 CAN2 J1939 + DTC 250
 Calc HRFC Active Discard FF values

CAN Trailers:

Use an EasyCAN adapter to connect to the Trailer CANbus data line. Set baudrate to 125. Do not forget to enable appropriate IO parameters (they start with keyword "Trailers").

Event on Monitoring
 CAN2 Trailers 125
 Active

1-Wire DS1971:

Use the 1-Wire interface to enable and configure DS1971 iButton EEPROM memory reading. This process is described in the "Drivers registration" document located [here](#).

Include data only on event
 1-Wire DS1971 Config

Digital outputs section

DOUT1 and **DOUT2** – dropdown lists let you choose one of the following: "Disabled", "LED", "Buzzer", "Blocking", "GSM jamming block", "Custom".

More information available on our documentation [website](#).

IO counters
Records on event: 1
DOUT1 Disabled
DOUT2 Disabled

DIN3 & DIN 4 mode configuration

DIN3 and DIN4 can be set to work as either "Positive mode" (Positive trigger) or "Ground mode" (Negative trigger).

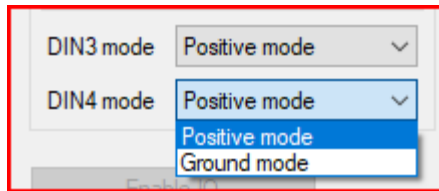

Ground mode (Negative trigger) - This mode sets the DIN as a positive terminal, in this case a peripheral/button connected to the DIN must be connected to Ground on the other end.

Positive mode (Positive trigger) – is the default mode of a DIN, it is set as a ground terminal, in this case a peripheral/button connected to the DIN must be connected to a power source.
 DIN mode selection depend solely on the peripheral devices/or buttons/or other accessories connected to that specific DIN. A connection example for both connection modes for DIN3 is shown below (The same connection method works for DIN4).



4.4 Integration protocol

All integration related questions and documentation can be acquired from Ruptela technical support: support@ruptela.com

5 Installation recommendations

5.1 Device installation

When installing device into a vehicle please obey these instructions, otherwise your device may not work properly.

- Device should not be seen or easily reached.
- Device should be firmly fixed to a flat surface. Please avoid mounting it near the metal surfaces or cables (see the picture below).
- Device cannot be fixed to heat emitting or moving parts.
- Device has built in accelerometer, therefore it is sensitive to movement. It is recommended to choose a stable installation position, where it is not subjected to vibrations and/or oscillations.
- Device can be fitted with double sided stick tape or zip-ties.
- Wrong device mounting may cause malfunction.
- SIM card should be inserted in the device while the connector is plugged off (while device has no power).

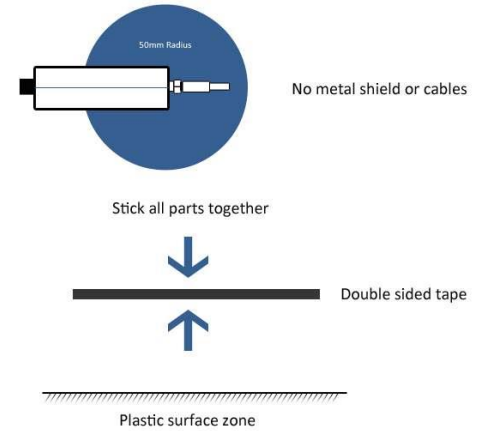

5.2 FM-Tco4 HCV BT device

Your FM-Tco4 HCV BT device contains Bluetooth module. Choose installation location carefully. Approximate Bluetooth module position within the device is marked in the picture on the right. To ensure the best possible connectivity between Bluetooth devices follow these steps:

- FM-Tco4 HCV BT device with Bluetooth module should be installed facing up.
- Please avoid mounting it near metal surfaces or cables.



5.3 Antenna installation

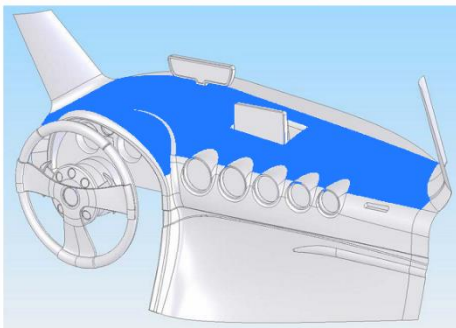

It is recommended to place GPS/GLONASS antenna behind the dashboard as close to the window as possible.